

Vehicle Emission Control System

Dr. Eng. Ramzi R .Barwari
**Assist .Professor /Thermal Power/Refrigeration &Air-
conditioning**
Consultant Engineer
Salahaddin University/College of Engineering
Mechanical Engineering Department
Director Administration of Hadyab Society
for Competencies
Erbil-Iraq
Mobile [+964\(0\)750 434 9609](tel:+964(0)7504349609)
[Email:ramzi.raphael@gmail.com](mailto:ramzi.raphael@gmail.com)
ramzi.ibraheem@su.edu.krd
ramzi.ibraheem@cihanuniversity.edu.iq
hsfcas@gmail.com

Emission Control

Exhaust Emissions are produced by cars, buses, and motorcycles.



Four basic types of exhaust emissions:

1. Hydrocarbons (HC)
2. Carbon monoxides (CO)
3. Oxides of nitrogen (NO_x)
4. Particulates.

Emission Control

Hydrocarbons (HC)

- Resulting from the release of unburned fuel into the atmosphere.
- Produced by incomplete combustion or by fuel evaporation.
- Mostly related to ignition problems.
- Effect could be eye, throat, and lung irritation, and, possibly cancer.

Carbon Monoxide (CO)

burned fuel (*incomplete combustion of petroleum-based fuel*).

- A rich air-fuel would increase CO; lean air-fuel mixture would lower CO emissions.

Symptoms of carbon monoxide (CO)

- CO prevents human blood cells from carrying oxygen to body tissue.

Symptoms are headaches, nausea, blurred vision, and fatigue

Emission Control

Oxides of Nitrogen (NOx)

- Produced by extremely high temperatures during combustion.
- Air consist of about 79% nitrogen and 21% oxygen.
- With enough heat (above 2500°F / 1370°C), nitrogen and oxygen in air-fuel mixture combines to form NOx emissions.
- An engine with high compression ratio, lean air-fuel mixture, and high-temperature thermostat will produce high combustion heat, resulting in formation of NOx.

Emission Control

SOURCES OF VEHICLE EMISSIONS

- **Engine Crankcase Blow-by Fumes (20%)** – heating oil and burning of fuel that blows past piston rings and into the crankcase.



- **Fuel Vapour (20%)** – chemicals that enter the air as fuel evaporate.

- **Engine Exhaust (60%)**- blown out the tailpipe when engine burns a hydrocarbon based fuel.

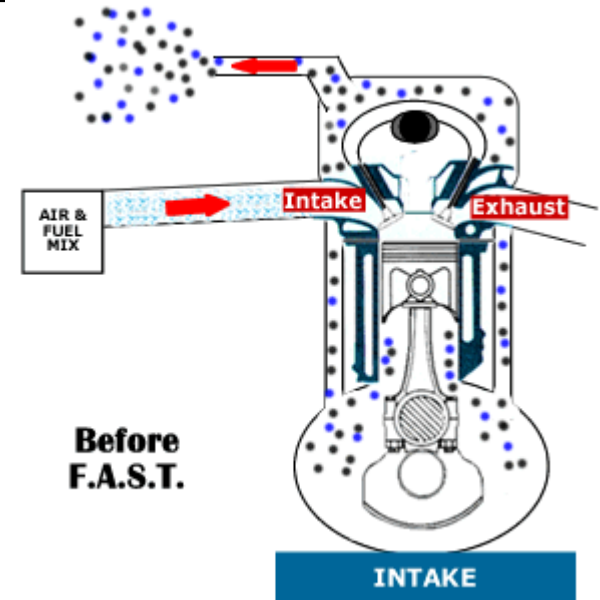

Engine Modification Related to Emission Control

Lower Compression Ratios

- Use of unleaded gasoline that permits use of catalytic converters and burns completely to lower **HC** emissions.
- Lower combustion temperature = Lower **NOx** emissions.

Smaller Combustion Chamber Surface Volume

- Reduce **HC** emissions.
- Lowers the amount of heat dissipation out of the fuel mixture.
- Reduce the chance of fuel condensation.

Reduce Quench Areas in the Combustion Chambers

- Lower **HC** and **CO** emissions.
- Quench areas- movement of piston too close to the cylinder head.
- If too close, it tends to quench (*put out*) combustion and increase emissions due to unburned fuel.

Vehicle Emission Control System

Exhaust Gas Recirculation (EGR)

- Allows burned gases to enter the engine intake manifold to help reduce **NOx**
- When exhaust gases are added to air-fuel mixture, they decrease peak combustion temperatures.



Vehicle Emission Control System

Air Injection System

- Forces fresh air into the exhaust ports or catalytic converter to reduce **HC/CO**.
- Oxygen from the air injection system causes the unburned fuel to burn in the exhaust system or the catalytic converter.

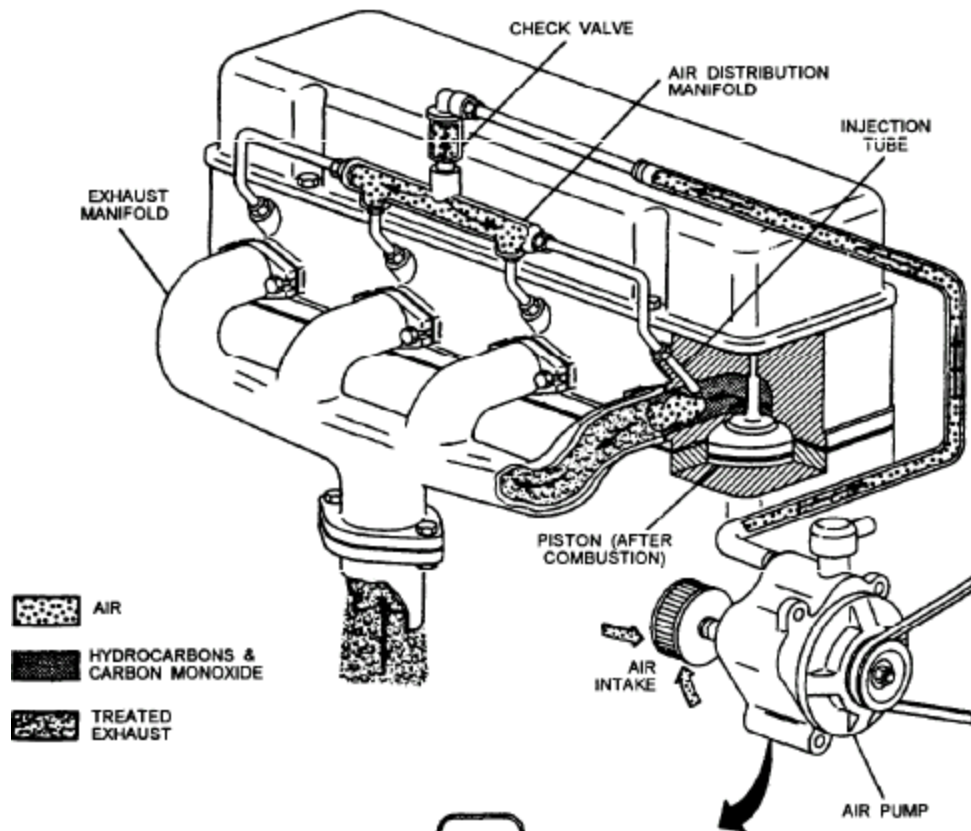

Vehicle Emission Control



Catalytic Converter

- Oxidizes (burns) the remaining **HC** and **CO** emissions that pass into the exhaust system.
- Extreme heat (1400°F/760°C) ignites these emissions and change them into carbon dioxide (**CO₂**) and water (**H₂O**).
- Catalyst** is a substance that speeds a chemical reaction without itself being changed (coated with ceramic honey comb).
- Catalyst Substance:** **Platinum** and **Palladium** treats **HC** and **CO** emissions; **Rhodium** acts on the **NO_x** emissions.

Catalytic Converter

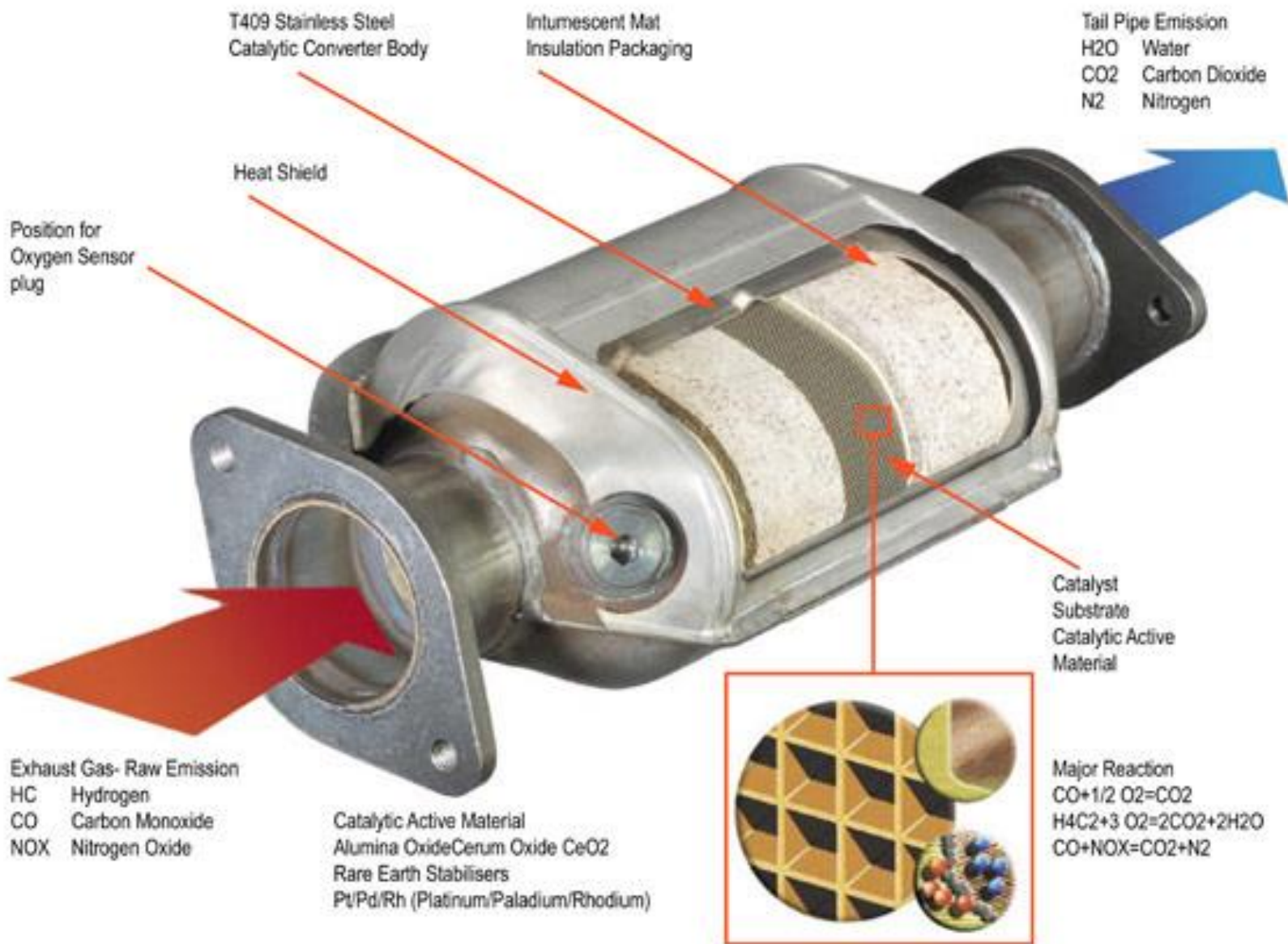

Vehicle Emission Control System

Types of Converters

Mini Catalytic Converter is placed close to the engine exhaust manifold.



Two-way Catalytic Converter can only reduce **HC & CO** (Platinum).



Vehicle Emission Control System

Types of Converters

Three-way Catalytic Converter

reduces **HC**, **CO** & **NO_x** (Platinum and Rhodium).

Dual-bed Catalytic Converter

normally has both a three-way (reduction) and a two-way (oxidation) catalyst.

- Mixing chamber is provided between the two.
- Air is forced into the mixing chamber to help burn the **HC** and **CO** emissions.

CATALYTIC CONVERTER

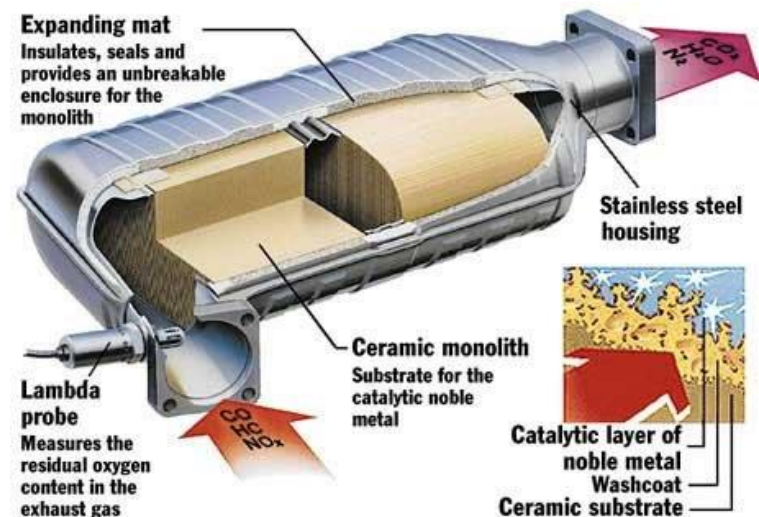
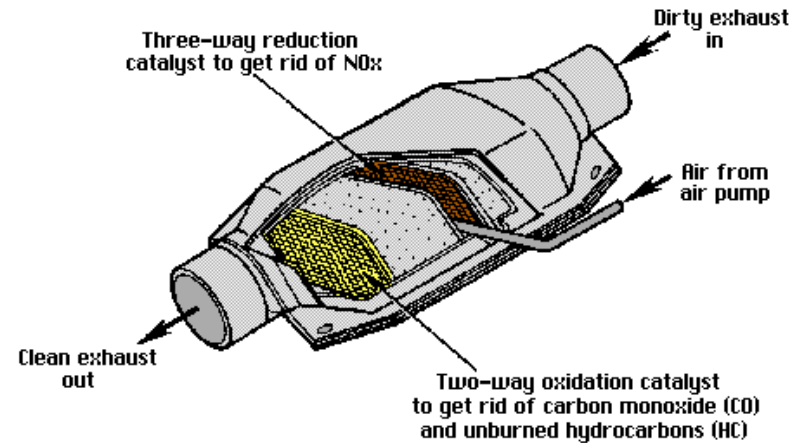

Thank you for
your attention

**Any
Questions ?**