

Cihan University
College of Engineering
Department of Communication and
Computer Engineering

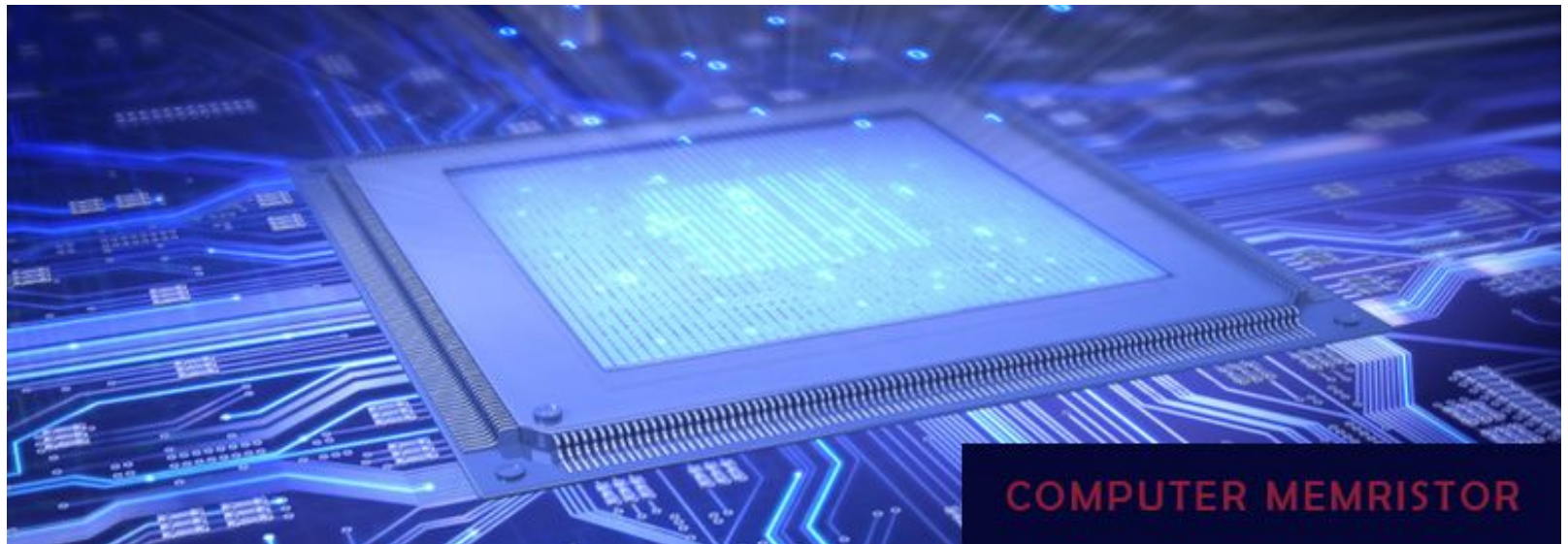

Realization of Biquadratic Filter Using Memristor

By: Sakar JAMEEL



INTRODUCTION

- In this seminar, a brief review of the memristor and its terminal equations are given.
- Biquadratic filter implementation with memristor is introduced.
- SPICE sub-circuit model is presented to simulate the memristor. Gain and phase characteristics of the proposed biquadratic filter are obtained with SPICE circuit simulator.
- It is observed that filter parameter such as cut off frequencies, band width, quality factor are adjustable by memristor parameters and the power consumption of the biquadratic filter with memristor is low and has better efficiency.

- The new building block for electrical circuit founded is memristor which is the fourth passive element [1].
- The memristor carries memory from of its past. When the electric circuit's voltage is turned off the memristor still remembers the amplitude and the duration of voltage applied on it.
- The device was physically published in Hewlett Packard Labs in 2008 [2].
- It is defined as relationship between two of the four fundamental circuit variables, namely the current i , the voltage v , the charge q and the flux Φ , memristor provides a functional relation between charge and flux as,

$$d\phi = M dq$$

- In both realization, the SPICE model of memristor will be used and the i-v characteristics, independence variations of the circuits will be obtain by using SPICE.

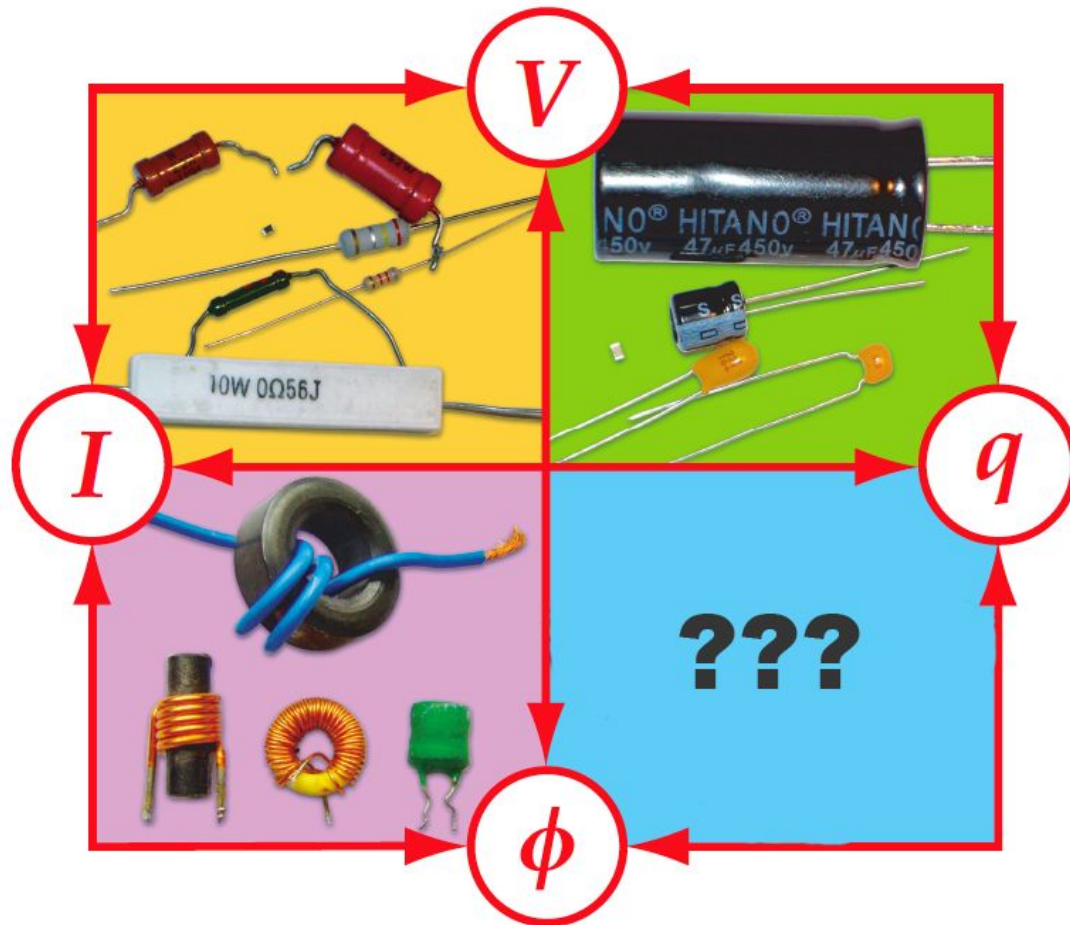

- that's mean is not a storage device of energy, so the voltage must equal to zero whenever the current goes to zero. This causes the I-V curve of the device to produce a drawn hysteresis loop, through that device has a memory effect linked with it.
- It is not storage energy element but the flux between the two terminals is a function of the amount of electric which is charge that has passed through the device.

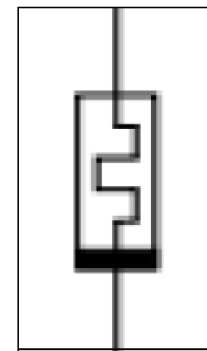

Figure 1 Symbol of memristor

- There was so much application and research about the memristor. It is used to perform analog arithmetic operation to realize the chaotic circuit
- In many electronic applications and communication systems, filters have important role.
- In the realization of analog filter the active and/or passive elements are commonly used to differentiate the signals.
- This is generally achieved by well known circuit elements such as resistor, capacitor, inductors, operational amplifiers, etc.
- Any order filter can be realized by cascading first or/and second (biquadratic) order filter blocks.

- Types of Memristor

- Titanium Dioxide Memristor
- Polymeric Memristor
- Spin Memristive Systems
- Manganite Memristive Systems
- Resonant Tunneling Diode Memristor

REALIZATION OF MEMRISTOR MODEL

- There are four fundamental circuit variables: voltage v , current i , charge q , and flux Φ .
- They can be combined two at the time in six possible ways.
- The memristor consists of thin film of TiO_2 sandwiched within two metal plates. It contains two regions R_{on} and R_{off} which is doped and undoped region and w describes the width of the model.
- When a voltage $v(t)$ is applied to the memristor, depending on voltage polarity, the dopants drift from low to high or high to low concentration.

- The i - v characteristic of memristor can be described by

$$v(t) = \left(R_{on} \left(\frac{w(t)}{D} \right) + R_{off} \left(1 - \frac{w(t)}{D} \right) \right) i(t)$$

- The rate of the width of the doped region is.

$$\frac{dw}{dt} = v_D + \frac{\eta \mu_v R_{on}}{D} i(t)$$

The structure of the memristor

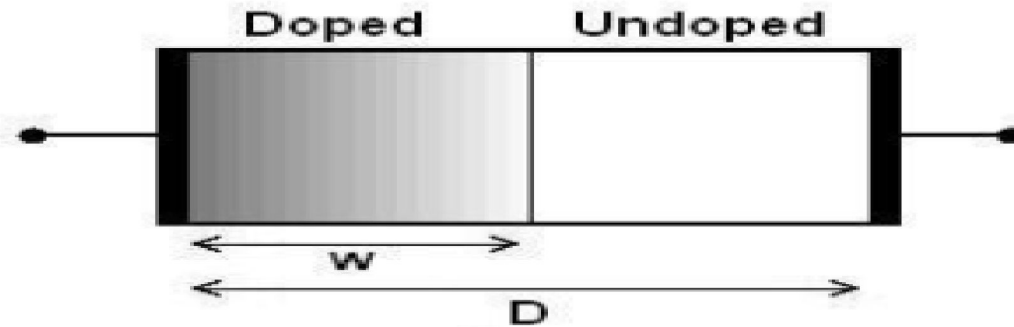

$$w(t) = w_0 + \frac{\eta \mu_v R_{on}}{D} q(t)$$

The initial resistance of the memristor is

$$R_o = R_{on} \left(\frac{w_o}{D} \right) + R_{off} \left(1 - \frac{w_o}{D} \right)$$

The charge that is required to pass through the memristor for the dopant boundary is given by

$$Q_o = \frac{D^2}{\mu_v R_{on}}$$

The difference between the undoped (off) and doped (on) resistance is

$$\Delta R = R_{off} - R_{on}$$

Since the charge is an invertible function of the magnetic flux as.

$$q(t) = \frac{Q_o R_o}{\Delta R} \left(1 - \sqrt{1 - \frac{2\eta \Delta R \varphi(t)}{Q_o R_o^2}} \right)$$

The memristor is defined as

$$M(q) = R_o \sqrt{1 - \frac{2\eta \Delta R \varphi(t)}{Q_o R_o^2}}$$

And i-v relation of memristor is written as

$$i(t) = \frac{v(t)}{R_o \sqrt{1 - \frac{2\eta \Delta R \varphi(t)}{Q_o R_o^2}}}$$

The hysteresis $i-v$ relation current i , and voltage v , of memristor are plotted as

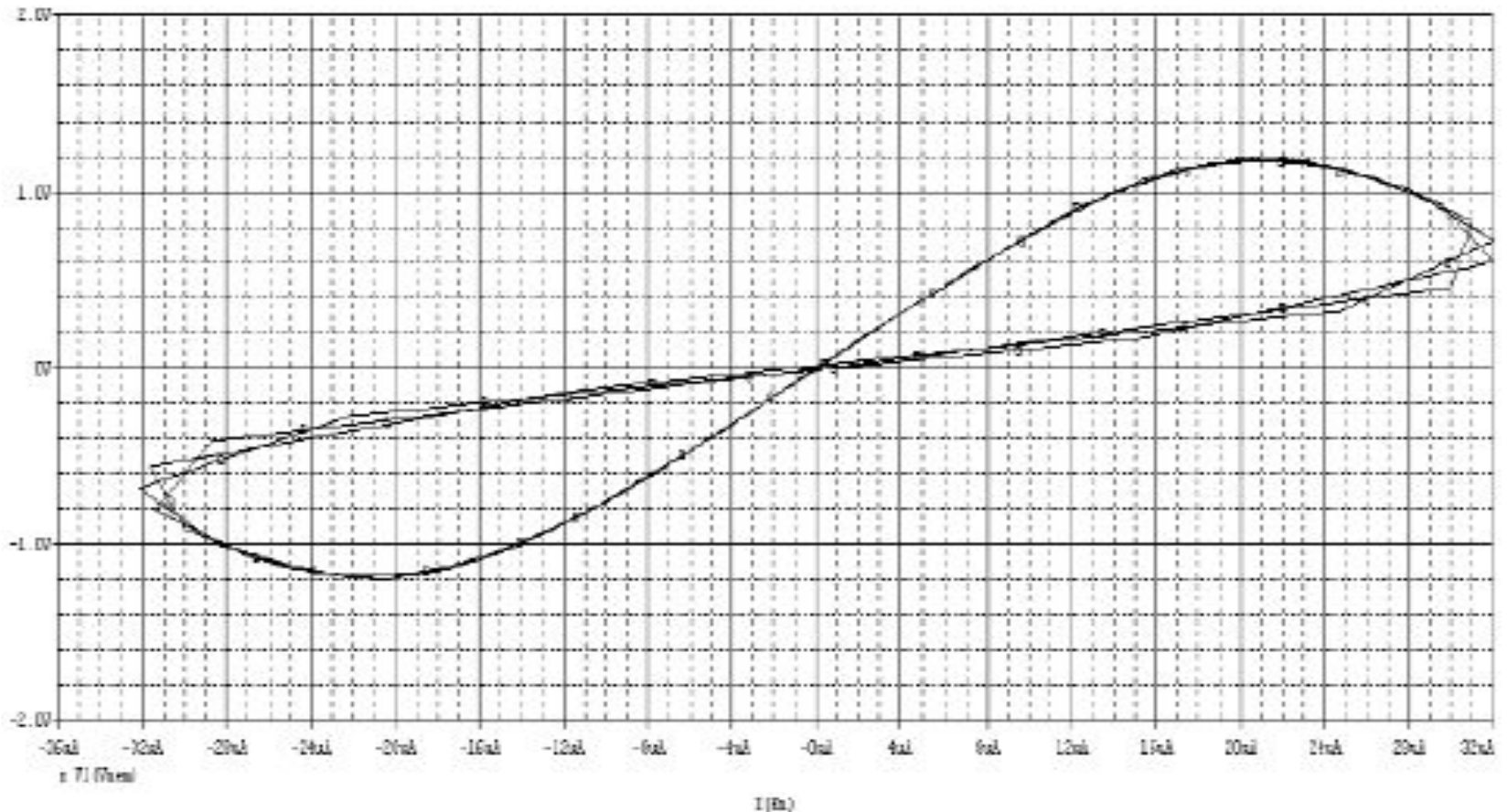

Voltage and current of memristor

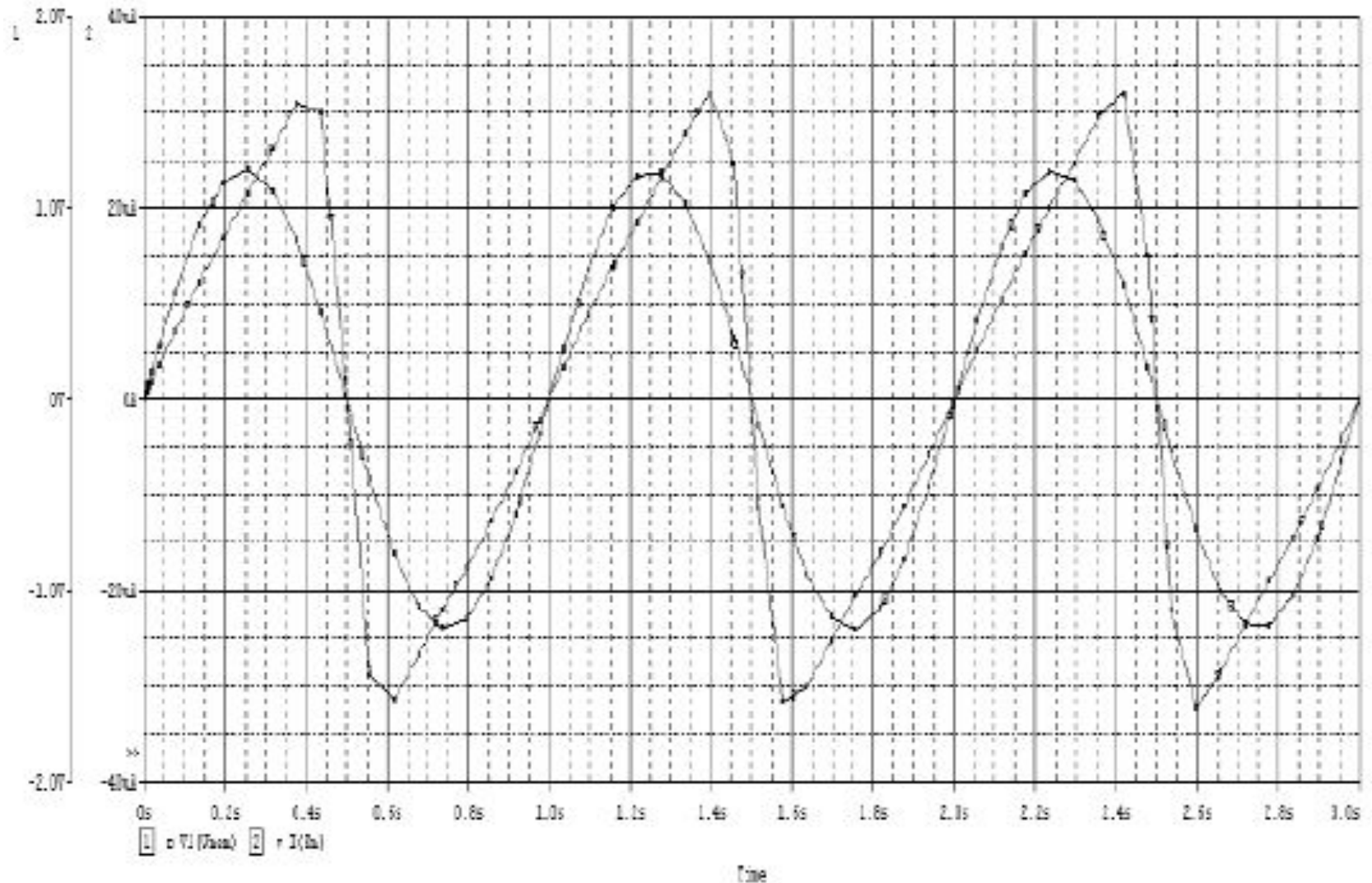

The general expression for the second order (biquadratic) transfer function is usually expressed in the standard form as

$$H(s) = \frac{k_1 s^2 + k_2 s + k_3}{s^2 + s\left(\frac{\omega_0}{Q}\right) + \omega_0^2}$$

where ω_0 is center frequency and Q is quality factor. The numerator $N(s)$ is k_{s^2} for high pass, k_s for band pass and k for low pass realization of the filter.

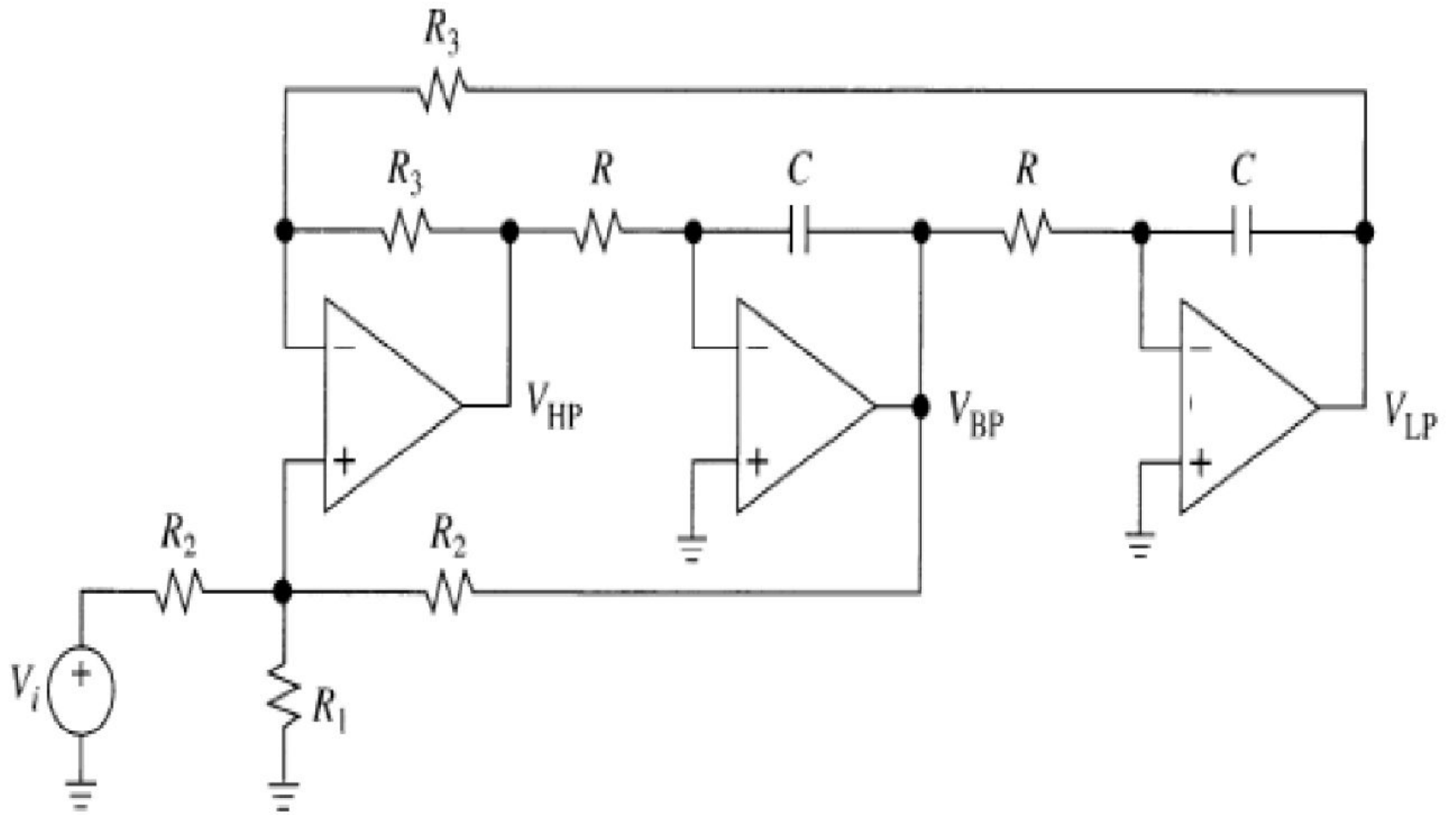
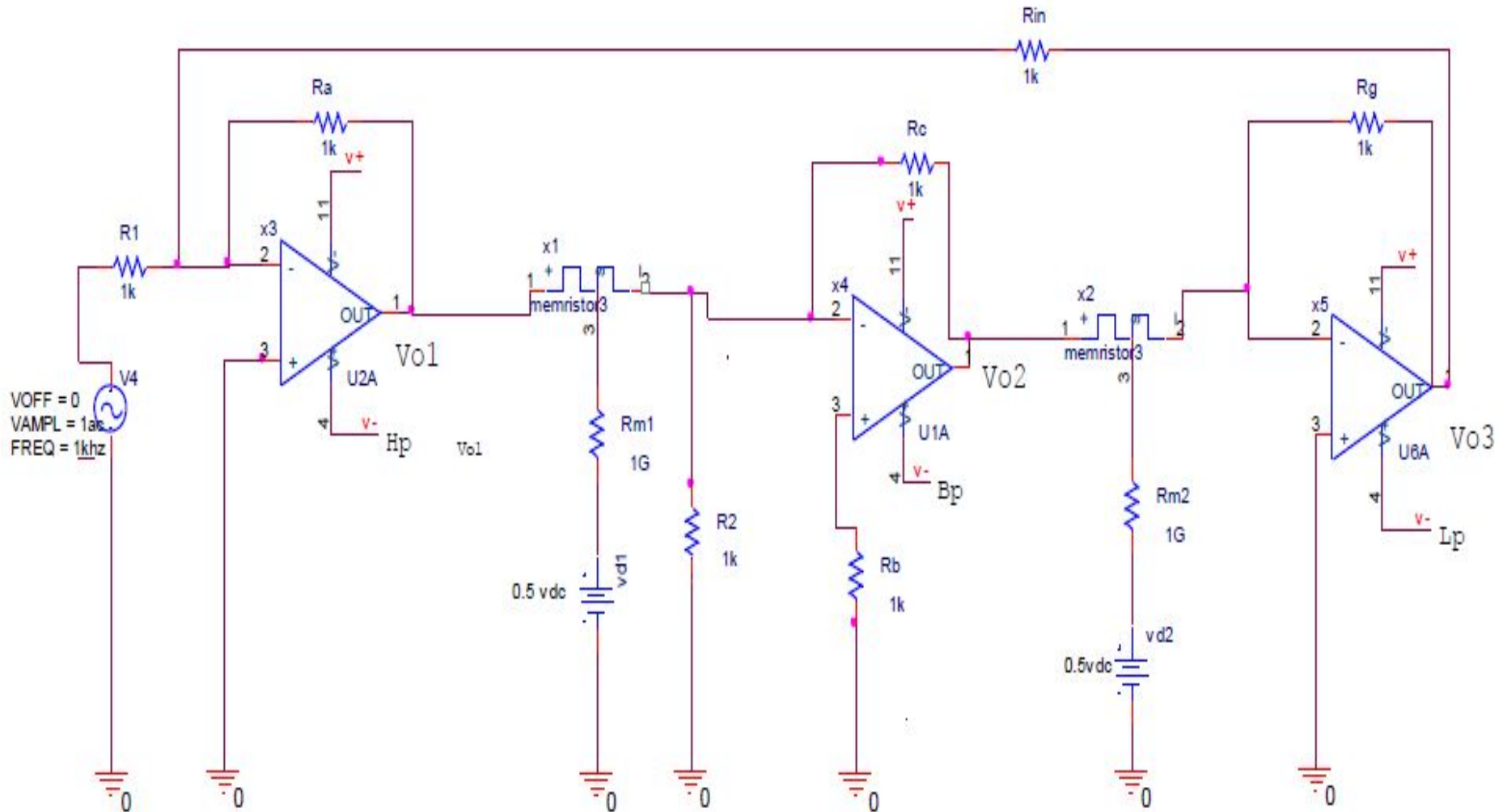
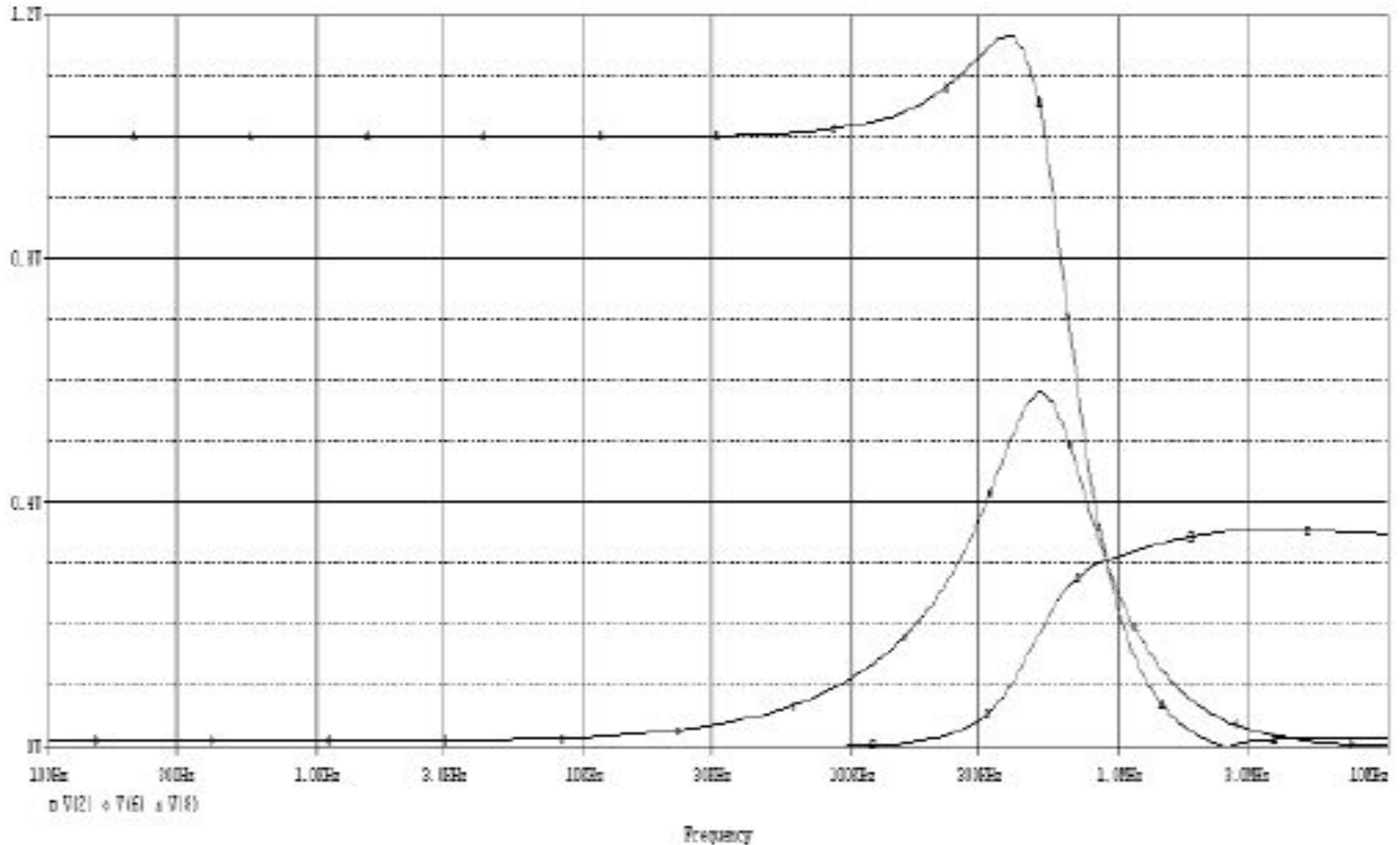

Figure biquadratic filter with RC element

Block diagram of biquadrate filter based on memristor



The gain of Lp, Hp, and Bp for given biquadratic circuit



CONCLUSION

- The implementation of biquadratic filter with memristor is introduced in this paper SPICE model of memristor is defined and simulation of the proposed filter is carried out with SPICE simulator.
- The use of memristors in the circuit improves the quality of the circuit from adaptability, low power consumption point of view
- A biquadratic filter structure is presented which contains only memristor and resistors and it is observed that fully integrated structure of the circuit results with less power consumption and easy control filter parameters.
- Is observed that the main characteristics of the filter such as cut-off frequency, gain and bandwidth can be controlled by changing the resistor of memristor.