

SEARCHING FOR OPTIMALITY IN SOLAR ENERGY: A CASE STUDY IN TURKEY

Presented by:

Dr. Qusay H. Al-Salami

*Department of Business Administration, College of
Administrative and Financial Sciences, Cihan
University - Erbil, Iraq*

15/11/2018

Abstract:

Although electricity plays an essential role in modern society, still there are about 1.2 billion people living without access to electricity, mostly living in rural areas of Africa and Asia.

This fact highlights the importance of generating electricity from distributed sources (like solar energy), where renewables have a large presence, to meet local demands in such rural areas.

What is Solar Energy?

Sunlight is a renewable energy source which can be converted into usable energy by solar panels.

There are two main types of solar energy:

1. Solar Photovoltaic (PV): panels directly convert solar energy into a usable form of energy using a PV cell containing a semiconductor material.

From a solar cell to a PV System



Solar Cell



Solar Module

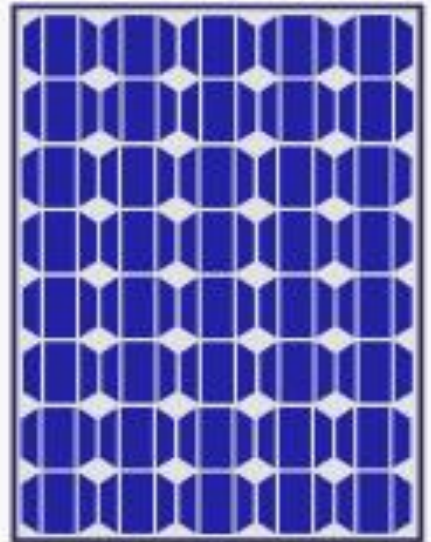

Solar Panel

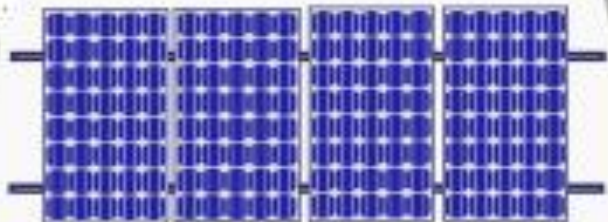

Solar Array

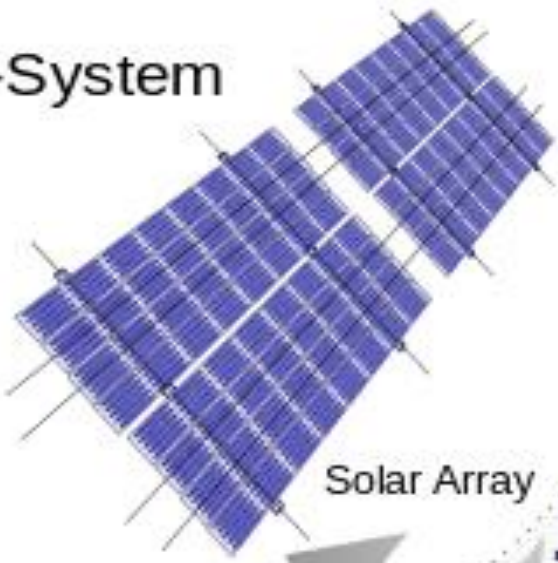

PV-System

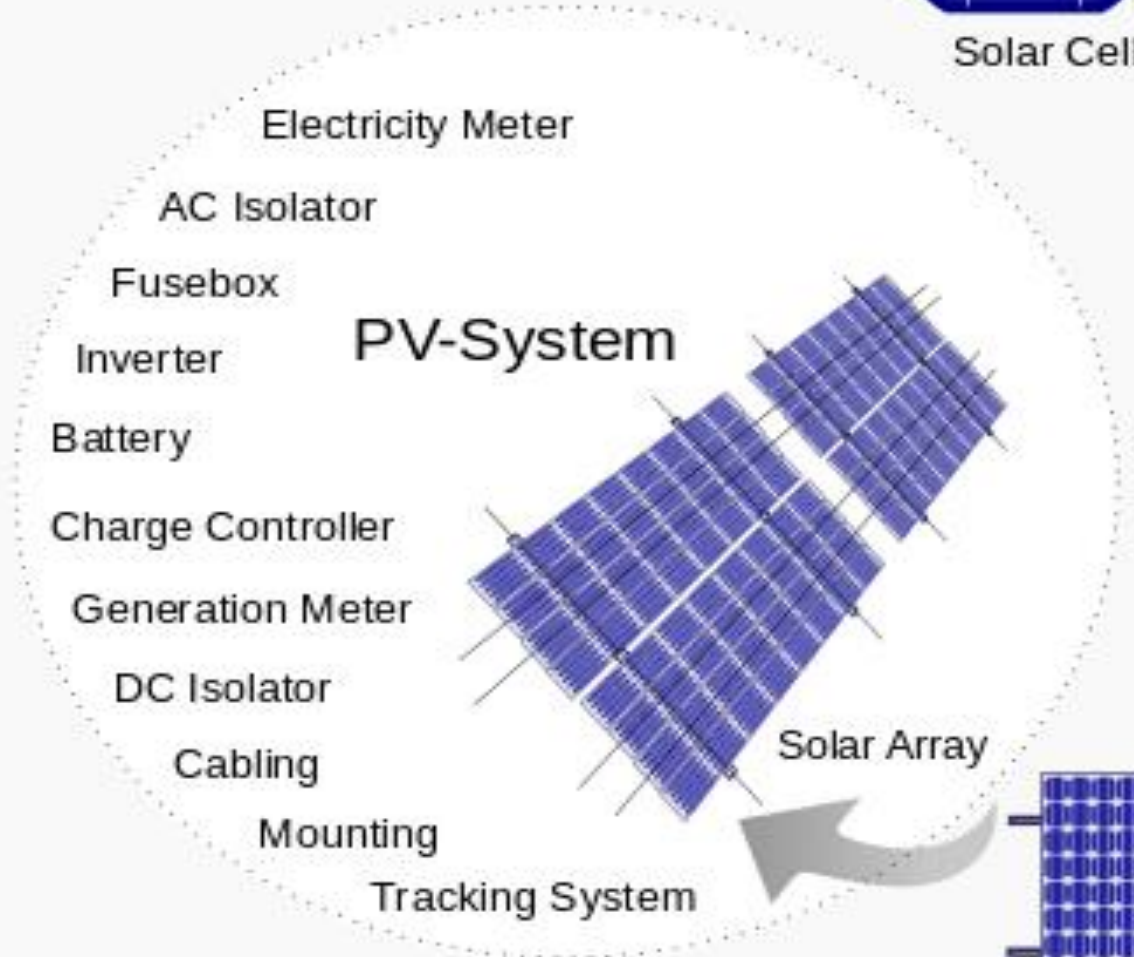

2. **Concentrating Solar Power** (CSP): concentrate energy from sunlight to a heat receiver which transforms energy from heat into mechanical energy, and in turn, solar thermal electricity.



Various Advantages of Solar Energy:

1. It's a renewable resource.
2. It's eco-friendly.
3. Can enhance the value of a home.
4. Requires little maintenance.
5. Easy installation.
6. Can be used in remote locations.
7. Solar cells make no noise at all and there are no moving parts.

Disadvantages of Solar Power:

1. It's not 100% reliable.
2. High initial capital costs.
3. Problem of efficiency.
4. Complications when moving.
5. Materials used to make solar panels can cause pollution.
6. Negative energy balance.
7. Installation area.

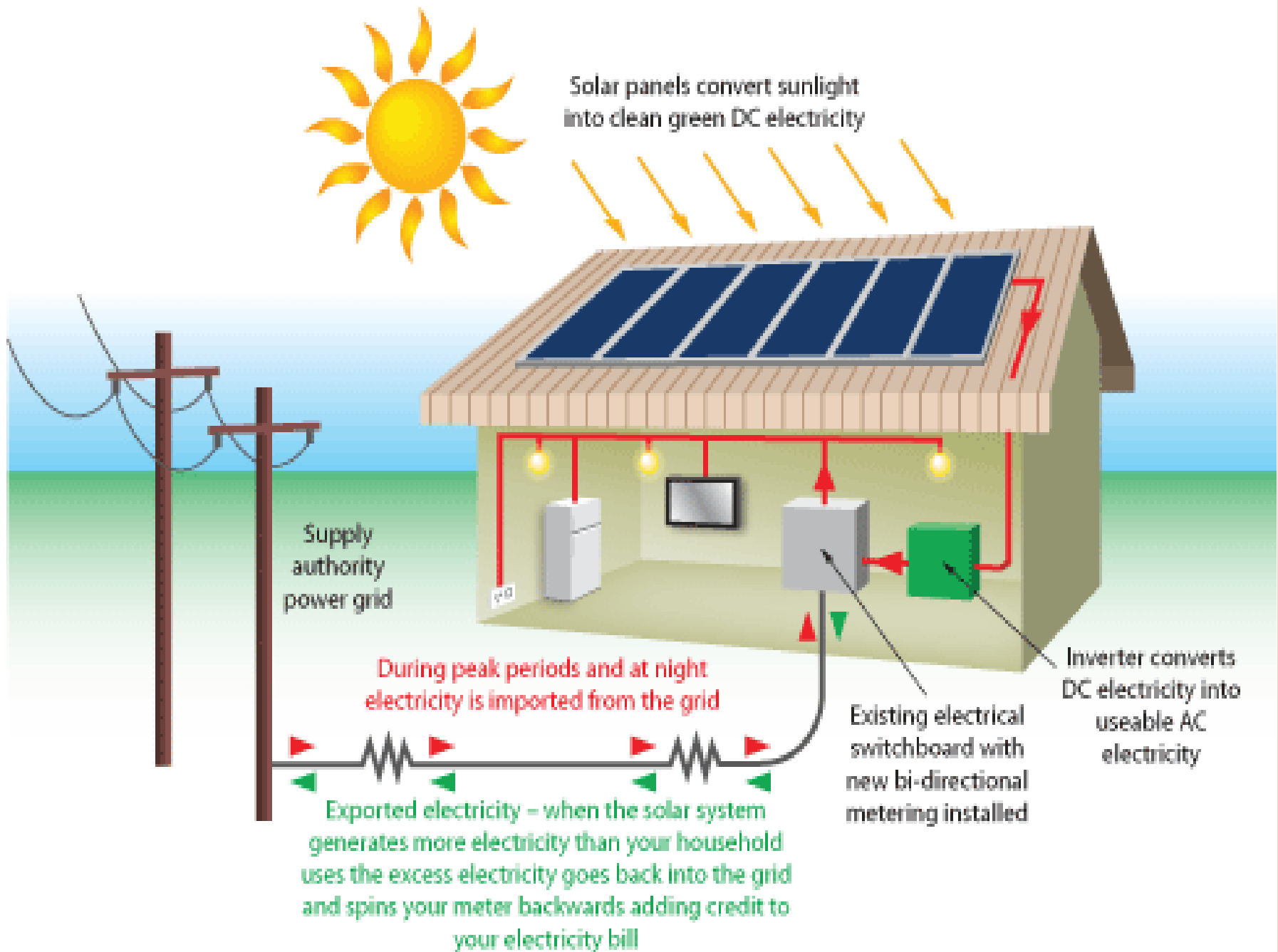

Examples of Solar energy design



Examples of Solar energy design

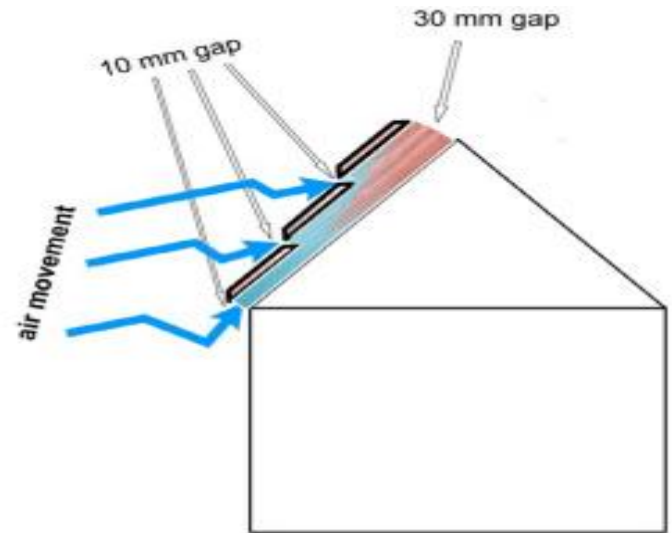
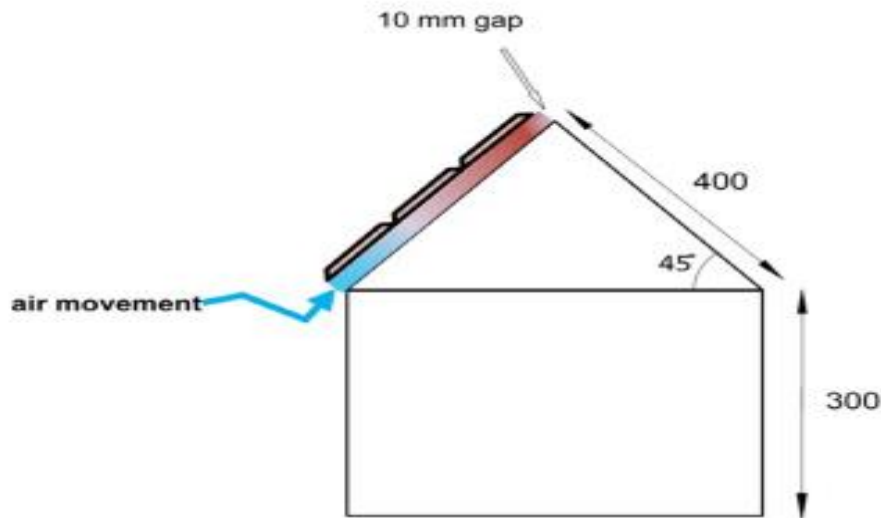
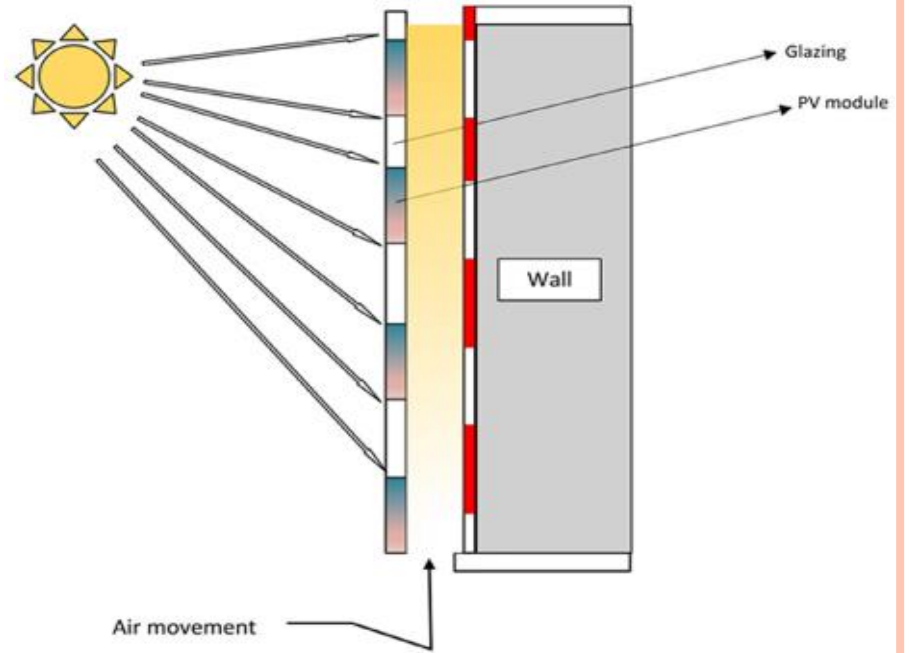
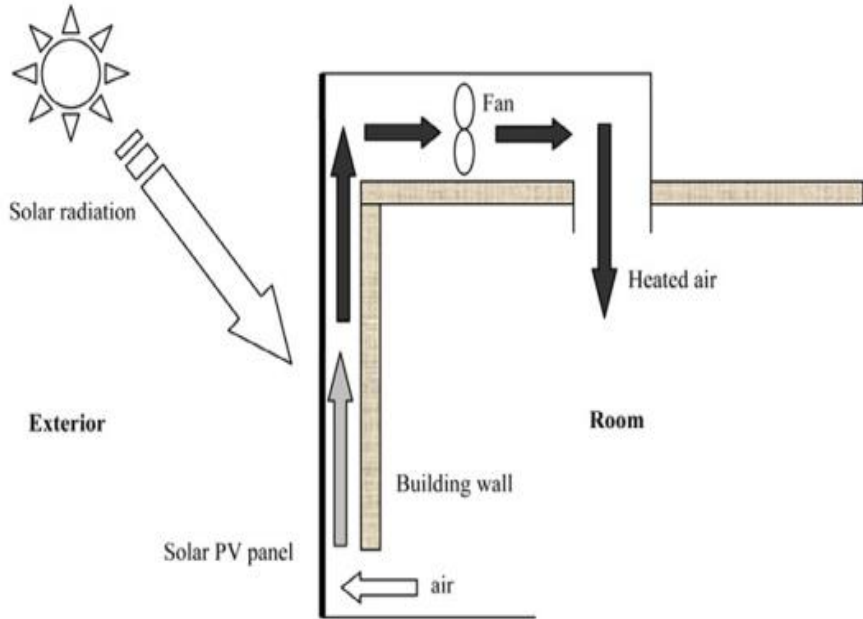

Other examples of Solar energy design



Optimum roof angle for solar panels

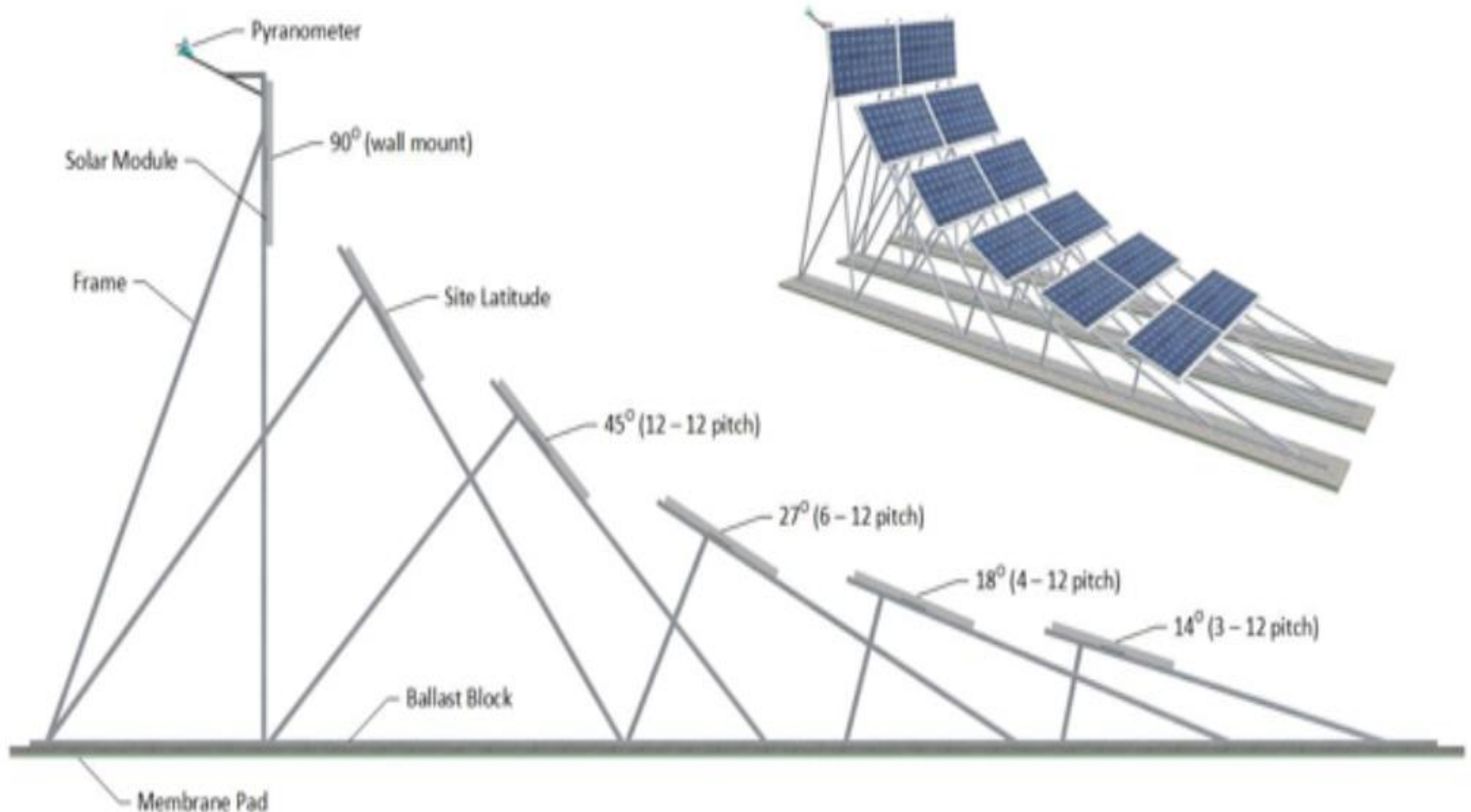

What is the Best Solar Panel Angle?

Literature review:

One of the most important paper is:

Optimization of Photovoltaic Power Self-Consumption using Linear Programming

The goal of the optimized controller is to reduce the overall costs by minimizing the individual amount of power purchased from the grid. This optimization problem can be formulated in linear terms and solved using linear programming (LP).

Solar Enrage in Turkey

SOLAR RESOURCE MAP

PHOTOVOLTAIC POWER POTENTIAL TURKEY



ESMAP

SOLARGIS



© 2017 THE WORLD BANK
Solar resource data: Solargis

Long term average of PVO_{UT} , period from 1994 (1999 in the East) to 2015

Daily totals:



Yearly totals:

1095	1241	1387	1534	1680	1826
------	------	------	------	------	------

This map is published by the World Bank Group, funded by ESMAP, and prepared by Solargis. For more information and terms of use, please visit <http://globalsolaratlas.info>.

Solar cells:

Solar cells are expected to grow in Turkey in the next few years as a result of Chinese companies' investment.

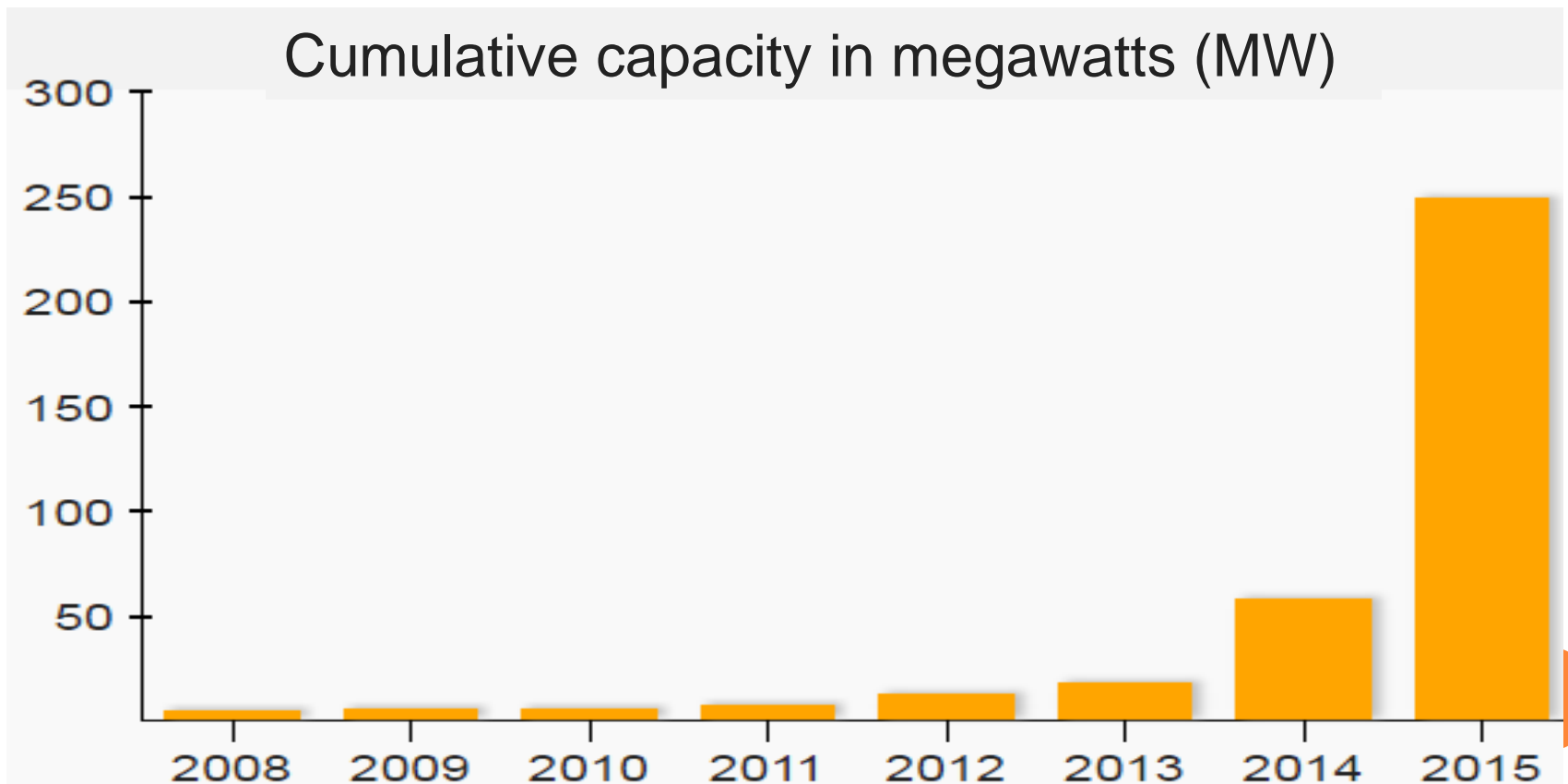

Orientation Chart showing yearly output for different orientation and tilt angles (%of maximum).

Tilt (°) from horizontal		Orientation - Compass bearing (°) measures from North												
		West			S.W.			South			S.E.			East
		270 °	255 °	240 °	225 °	210 °	195 °	180 °	165 °	150 °	135 °	120 °	105 °	90 °
0 °	90	90	90	90	90	90	90	90	90	90	90	90	90	
10 °	89	91	92	94	95	95	96	95	95	94	93	91	90	
20 °	87	90	93	96	97	98	98	98	97	96	94	91	88	
30 °	86	89	93	96	98	99	100	100	98	96	94	90	86	
40 °	82	86	90	95	97	99	100	99	98	96	92	88	84	
50 °	78	84	88	92	95	96	97	97	96	93	89	85	80	
60 °	74	79	84	87	90	91	93	93	92	89	86	81	76	
70 °	69	74	78	82	85	86	87	87	86	84	80	76	70	
80 °	63	68	72	75	77	79	80	80	79	77	74	69	65	
90 °	56	60	64	67	69	71	71	71	71	69	65	62	58	
Vertical	Near horizontal 0 ° inclinations are not recommended as the self-cleaning cannot be relied on at less than about 10 °													

Research Problem:

What is the Best Solar Panel Angle?

Methodology:

We take in consideration:

1. All Turkish cities (80 cities) as a case study.
2. All solar panel's angle from 0 to 90.
3. All months during one year (2018).
4. Simulate the real case using Microsoft Office – Excel.



زهرة الالواح الشمسية