

Date of publication xxxx 00, 0000, date of current version xxxx 00, 0000.

Digital Object Identifier 10.1109/ACCESS.2017.Doi Number

A High-Performance Microstrip Triplexer with Compact Size, Flat Channels and Low Losses for 5G Applications

Leila Nouri ¹, Farid Zubir ², Salah I. Yahya ^{3,4}, Abbas Rezaei ⁵, Fawwaz Hazzazi ⁶, Muhammad Akmal Chaudhary ⁷, Maher Assaad ⁷, Zubaida Yusoff ⁸, B.N. Nhu ¹

¹ Institute of Research and Development, School of Engineering & Technology, Duy Tan University, Da Nang, Vietnam

² Wireless Communication Centre, Faculty of Electrical Engineering, Universiti Teknologi Malaysia, 81310 Johor Bahru, Johor, Malaysia

³ Department of Communication and Computer Engineering, Cihan University-Erbil, Erbil, Iraq

⁴ Department of Software Engineering, Faculty of Engineering, Koya University, Koya KOY45, Iraq

⁵ Department of Electrical Engineering, Kermanshah University of Technology, Kermanshah, Iran.

⁶ Department of Electrical Engineering, College of Engineering in Al-Kharj, Prince Sattam bin Abdulaziz University, AlKharj 11492, Saudi Arabia

⁷ Department of Electrical and Computer Engineering, College of Engineering and Information Technology, Ajman University, United Arab Emirates

⁸ Faculty of Engineering, Multimedia University, Persiaran Multimedia, Cyberjaya, 63100 Selangor, Malaysia

Corresponding authors: Leila Nouri (leilanouri@duytan.edu.vn), Farid Zubir (faridzubir@utm.my), Zubaida Yusoff (zubaida@mmu.edu.my)

This work was funded by the Higher Institution Centre of Excellence (HICOE), Ministry of Higher Education Malaysia through Wireless Communication Centre (WCC), Universiti Teknologi Malaysia, Vot. No. R.J090301.7823.4J610.

ABSTRACT A new microstrip triplexer with a compact size of $0.007 \lambda_g^2$ is proposed in this work, where designing a microstrip triplexer with a size less than $0.01 \lambda_g^2$ is a big challenge. In addition to the compact size, it shows a high performance i.e. its channels are wide with low insertion losses. Moreover, the channels are flat with three low group delays (GDs) of 0.65, 0.95 and 1.17 ns, while most of the previously reported triplexers have not considered this important parameter. The proposed resonator is mathematically analyzed to find a method to get rid of harmonics and tune the resonance frequency. Meanwhile, the 1st, 2nd, 3rd and 4th harmonics are suppressed above the first channel. The designed triplexer is suitable for 5G mid-band applications. The proposed triplexer is exactly fabricated and then measured to confirm the designing method and simulation results. The obtained results show that all the simulation, mathematical analysis and experimental results are in good agreement. Therefore, the proposed triplexer can be easily used in designing high-performance RF communication systems.

INDEX TERMS Microstrip, Compact, Triplexer, Harmonic, 5G, Group delay.

I. INTRODUCTION

High-performance microstrip filtering devices such as couplers, diplexers and triplexers have been extensively applied in wireless RF communication applications [1-8]. In references [8-24], various types of microstrip planar resonators and triplexers are reported and all of them occupy large implementation areas greater than $0.01\lambda_g^2$. Coupled open-loops [8-9], coupled lines [10], coupled hairpin resonators [11], stub-loaded coupled open-loops [12] and coupled U-shapes [13] are some examples of using the coupling structure in designing microstrip components. Also, various mathematical analysis techniques have been employed in the design of microstrip triplexers such as: even and odd mode analysis [5], mathematical analysis of step impedance

resonators (SIR) [6], determination of lumped element values for a proposed microstrip structure [7], presentation of coupling matrices [8], calculation of input impedance for a three-channel filter [10] and obtaining Z-parameters for a presented resonator [13]. In [14], a triple-mode microstrip resonator is used to design a narrow-channel triplexer with high insertion losses. To design of a microstrip triplexer working at 1 GHz, 1.25 GHz and 1.5 GHz, coupled hairpin resonators are integrated in [15]. The introduced triplexer in [16] works at 2.67 GHz (4G LTE), 3.43 GHz and 3.1 GHz (IEEE802.16 WiMAX). In [17], a microstrip triplexer with coupled zigzag lines is introduced for WLAN and GSM applications. Open-loops are used to design a microstrip diplexer and a microstrip triplexer in [18]. Similar to reference [15], microstrip coupled hairpin resonators are used to design

a triplexer in [19]. But this microstrip triplexer occupies a very large implementation area of $0.119 \lambda_g^2$. Another common problem of the proposed triplexers in [18-21] is having large insertion losses. A microstrip channel-continuous triplexer with high insertion losses and several transmission zeroes is presented in [22]. Coupled loops with internal coupled lines are used to achieve a microstrip triplexer in [23]. An important factor of a well-designed passive filtering device is having low group delay (GD). Because the group delay is a type of distortion that can change the shape of a signal. Despite this fact, none of the previous triplexers tried to decrease group delays significantly. Therefore, as a general result it can be said that most of the previous triplexers have large dimensions and high losses. Moreover, none of the previous designs has made any efforts to improve the group delays significantly. Accordingly, we will try to solve these problems by introducing a new structure. Our aim is to obtain a new microstrip triplexer with low losses, low group delays, flat channels and a very compact size that can be easily used in designing high-performance RF communication systems. We will present a perfect mathematical design method to analyze a new proposed resonator. This method includes calculating the ABCD matrix and extracting the scattering parameters. Then, three bandpass filters (BPFs) will be designed based on the analyzed resonator. By integrating these filters, a new microstrip triplexer for 5G mid-band applications will be obtained.

II. DESIGN OF PROPOSED TRIPLEXER

To obtain a microstrip triplexer, we need to design a new microstrip resonator. Our proposed resonator is a stub-loaded line coupled to a transmission line. Fig.1 shows our resonator, its approximated LC circuit and its simplified LC circuit. The open ends of the coupled lines are presented by the capacitors C_o . The equivalent of the coupling effect is approximated by a small capacitor of C , which is usually in the fF range. The lines indicated by the lengths l_a and l_b are replaced by the inductors L_a and L_b respectively. Also, the impedance of the shunt stub is shown by Z_s .

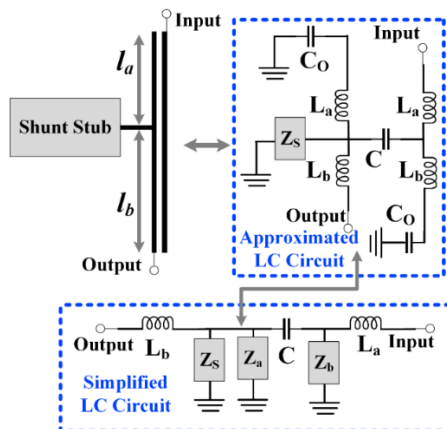

FIGURE 1. Proposed new resonator with its approximated LC circuits.

In the simplified LC circuit, the impedances Z_a and Z_b are given by:

$$Z_a = j\omega L_a + \frac{1}{j\omega C_o} \quad (1)$$

$$Z_b = j\omega L_b + \frac{1}{j\omega C_o}$$

The ABCD matrix from the input port to the output port (T) can be written as:

$$T = \begin{bmatrix} A & B \\ C & D \end{bmatrix} = \begin{bmatrix} 1 & j\omega L_a \\ 0 & 1 \end{bmatrix} \times \begin{bmatrix} 1 & 0 \\ \frac{1}{Z_b} & 1 \end{bmatrix} \times \begin{bmatrix} 1 & \frac{1}{j\omega C} \\ 0 & 1 \end{bmatrix} \times \begin{bmatrix} 1 & 0 \\ \frac{1}{Z_s + Z_a} & 1 \end{bmatrix} \rightarrow$$

$$A = 1 + \frac{j\omega L_a}{Z_b} + \left(\frac{1}{j\omega C} + \frac{L_a}{CZ_b} + j\omega L_a\right) \left(\frac{1}{Z_s} + \frac{1}{Z_a}\right) \quad (2)$$

$$B = \frac{1}{j\omega C} + \frac{L_a}{CZ_b} + j\omega L_a + j\omega L_b \left[1 + \frac{j\omega L_a}{Z_b} + \left(\frac{1}{j\omega C} + \frac{L_a}{CZ_b} + j\omega L_a\right) \left(\frac{1}{Z_s} + \frac{1}{Z_a}\right)\right]$$

$$C = \frac{1}{Z_b} + \frac{1}{Z_s} + \frac{1}{Z_a} + \frac{1}{j\omega CZ_b Z_s} + \frac{1}{j\omega CZ_b Z_a}$$

$$D = j\omega L_b \left[\frac{1}{Z_b} + \left(1 + \frac{1}{j\omega CZ_b} \left(\frac{1}{Z_s} + \frac{1}{Z_a}\right)\right) + \left(1 + \frac{1}{j\omega CZ_b}\right)\right]$$

By substituting (1) in (2), the following equations can be obtained:

$$A = 1 + \frac{j\omega L_a}{j\omega L_b + \frac{1}{j\omega C_o}} + \left(\frac{1}{j\omega C} + \frac{L_a}{C(j\omega L_b + \frac{1}{j\omega C_o})} + j\omega L_a\right) \left(\frac{1}{Z_s} + \frac{1}{j\omega L_a + \frac{1}{j\omega C_o}}\right)$$

$$B = \frac{1}{j\omega C} + \frac{L_a}{C(j\omega L_b + \frac{1}{j\omega C_o})} + j\omega L_a + j\omega L_b \left[1 + \frac{j\omega L_a}{j\omega L_b + \frac{1}{j\omega C_o}} + \left(\frac{1}{j\omega C} + \frac{L_a}{C(j\omega L_b + \frac{1}{j\omega C_o})} + j\omega L_a\right) \left(\frac{1}{Z_s} + \frac{1}{j\omega L_a + \frac{1}{j\omega C_o}}\right)\right]$$

$$C = \frac{1}{j\omega L_b + \frac{1}{j\omega C_o}} + \frac{1}{Z_s} + \frac{1}{j\omega L_a + \frac{1}{j\omega C_o}} + \frac{1}{j\omega C(j\omega L_b + \frac{1}{j\omega C_o})Z_s} + \frac{1}{j\omega C(j\omega L_b + \frac{1}{j\omega C_o})(j\omega L_a + \frac{1}{j\omega C_o})}$$

$$D = j\omega L_b \left[\frac{1}{j\omega L_b + \frac{1}{j\omega C_o}} + \left(1 + \frac{1}{j\omega C(j\omega L_b + \frac{1}{j\omega C_o})} \left(\frac{1}{Z_s} + \frac{1}{j\omega L_a + \frac{1}{j\omega C_o}}\right)\right) + 1 + \frac{1}{j\omega C(j\omega L_b + \frac{1}{j\omega C_o})}\right] \quad (3)$$

If we select the shunt stub as a low-impedance section, then:

$$\frac{1}{Z_s} + \frac{1}{j\omega L_a + \frac{1}{j\omega C_o}} \approx \frac{1}{Z_s} \quad (4)$$

$$\frac{1}{Z_s} + \frac{1}{j\omega L_a + \frac{1}{j\omega C_o}} \approx \frac{1}{Z_s}$$

$$\frac{1}{j\omega L_b + \frac{1}{j\omega C_o}} + \frac{1}{Z_s} + \frac{1}{j\omega L_a + \frac{1}{j\omega C_o}} \approx \frac{1}{Z_s}$$

As mentioned before, C is a small capacitor in the fF range. On the other hand, ω is our predetermined angular frequency which is in the GHz range. For achieving this frequency, we have to choose the values of inductors in the nH range. Therefore, we can use other approximations as follows:

$$\frac{1}{j\omega C} + \frac{L_a}{C(j\omega L_b + \frac{1}{j\omega C_o})} + j\omega L_a \approx \frac{1}{j\omega C} + \frac{L_a}{C(j\omega L_b + \frac{1}{j\omega C_o})} = \frac{1}{j\omega C} \left(1 + \frac{L_a}{L_b - \frac{1}{\omega^2 C_o}}\right) \quad (5)$$

$$\frac{1}{j\omega C(j\omega L_b + \frac{1}{j\omega C_o})Z_s} \gg \frac{1}{j\omega C(j\omega L_b + \frac{1}{j\omega C_o})(j\omega L_a + \frac{1}{j\omega C_o})} + \frac{1}{j\omega L_b + \frac{1}{j\omega C_o}} + \frac{1}{Z_s} + \frac{1}{j\omega L_a + \frac{1}{j\omega C_o}}$$

By applying the above approximations and also by using (4) and (5), (3) can be summarized as follows:

$$A \approx \frac{1}{j\omega CZ_s} + \frac{L_a}{CZ_s(j\omega L_b + \frac{1}{j\omega C_o})} \quad (6)$$

$$B \approx \frac{L_b}{CZ_s} + \frac{L_a L_b \omega}{CZ_s(\omega L_b - \frac{1}{\omega C_o})}$$

$$C \approx \frac{1}{j\omega C(j\omega L_b + \frac{1}{j\omega C_o})Z_s}$$

$$D \approx \frac{L_b}{CZ_s(j\omega L_b + \frac{1}{j\omega C_o})}$$

Using the ABCD parameters, we can extract the scattering parameter S_{21} as follows [24]:

$$S_{21} = \frac{2CZ_s}{\frac{1}{j\omega} + \frac{2L_a}{(j\omega L_b + \frac{1}{j\omega C_o})} + \frac{L_b}{Z_o} + \frac{L_a L_b \omega}{Z_o(\omega L_b - \frac{1}{\omega C_o})} + \frac{Z_o}{C_o} - \omega^2 L_b} \quad (7)$$

As mentioned before, Z_s should have a low impedance and C has a very small value. Therefore, CZ_s has a small value near zero. To have a low insertion loss near zero, $|S_{21}|$ should be near 1. Therefore, the real and imaginary parts of the denominator of S_{21} should be zero. Accordingly, we can extract the conditions to have a low insertion loss as follows:

$$\frac{1}{j\omega} + \frac{2L_a}{(j\omega L_b + \frac{1}{j\omega C_o})} \approx 0 \rightarrow \omega_{r1} \approx \frac{1}{\sqrt{(2L_a + L_b)C_o}}$$

$$\frac{L_b}{Z_o} + \frac{L_a L_b \omega}{Z_o(\omega L_b - \frac{1}{\omega C_o})} + \frac{Z_o}{C_o} - \omega^2 L_b \approx 0 \rightarrow \omega_{r2} \approx \sqrt{\frac{L_b + Z_o^2 C_o}{L_b C_o (L_a + L_b)}} \quad (8)$$

Therefore, at the angular resonance frequencies ω_{r1} and ω_{r2} , the insertion losses can have the minimum values. According to (8) and for a predetermined angular resonance frequency, by increasing the coupling capacitor we can reduce the inductors L_a and L_b . Subsequently, reducing these inductors makes the physical length of the transmission line (l_a and/or l_b) shorter. To increase the coupling capacitor, the space between coupled lines can be reduced. But our aim is designing a resonator with only one resonance frequency, so ω_{r1} or ω_{r2} acts as a harmonic that must be eliminated. One way to eliminate this harmonic is to set both angular frequencies equal to each other. Based on this method, it can be written that:

$$\frac{1}{(2L_a + L_b)C_o} = \frac{L_b + Z_o^2 C_o}{L_b C_o (L_a + L_b)} \rightarrow L_a L_b + 2L_a Z_o^2 C_o + Z_o^2 C_o L_b = 0 \quad (9)$$

Due to the positive values of the inductors and capacitors, it is impossible to reach (9). So another method to eliminate the harmonic is putting it at high frequencies. To achieve this goal, the following equation can be used:

$$\frac{1}{(2L_a + L_b)C_o} \ll \frac{L_b + Z_o^2 C_o}{L_b C_o (L_a + L_b)} \rightarrow L_a L_b + 2L_a Z_o^2 C_o + Z_o^2 C_o L_b \gg 0 \quad (10)$$

According to the last equation, a high degree of freedom exists for shifting the harmonics to high frequencies. Therefore, our resonator is suitable to design of a triplexer. However, at first we designed three BPFs named BPF1, BPF2 and BPF3 using the analyzed stub-loaded coupled lines. These filters and their frequency responses are shown in Fig.2.

Since the input port will be common in the final triplexer layout, we didn't change its dimensions for all of the BPFs. The BPFs are simulated by ADS software using its EM simulator. A Rogers RT/duroid 5880 substrate with 31 mil thickness, $\epsilon_r = 2.22$ and 0.0009 loss tangent is used to simulate our filters. BPF1 has a 20 dB return loss and 0.08 dB insertion loss. It works at 2.95 GHz. The insertion loss of BPF3 at 1.4 GHz is 0.18 dB. The proposed BPFs are designed to be easily connected to each other. In BPF3, the length of coupled lines is short, which leads to a high insertion loss of 1.8 dB at 3.85 GHz. However, after connecting to other filters this factor can be improved.

By integrating the designed BPFs, the proposed microstrip triplexer is obtained as presented in Fig.3. As shown in this figure, we didn't change the dimensions of the designed BPFs. The size of our introduced triplexer is $15.5\text{mm} \times 12.3\text{mm} = 0.094\lambda_g \times 0.074\lambda_g$. We calculated λ_g (the guided wavelength) at 1.4 GHz.

To optimize the triplexer structure, we changed the significant lengths and widths presented in Fig.3 (l_1, l_2, l_3, w_1, w_2 and w_3). We selected them based on the results of the mathematical analysis of the proposed resonator and also the distribution of current density shown in Fig.4.

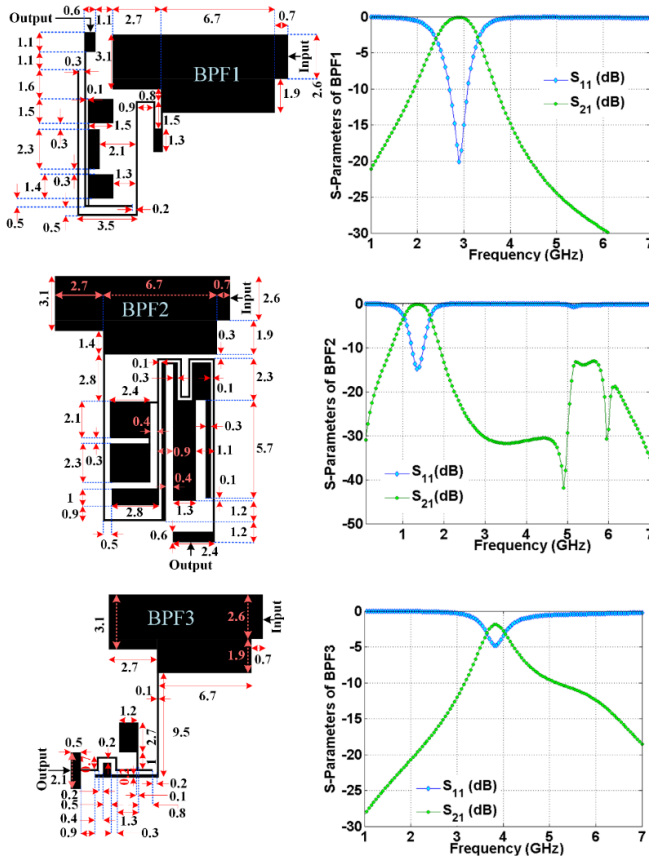

FIGURE 2. Proposed BPFs: layouts and frequency responses (Unit: mm and all the thinnest lines have widths of 0.1 mm).

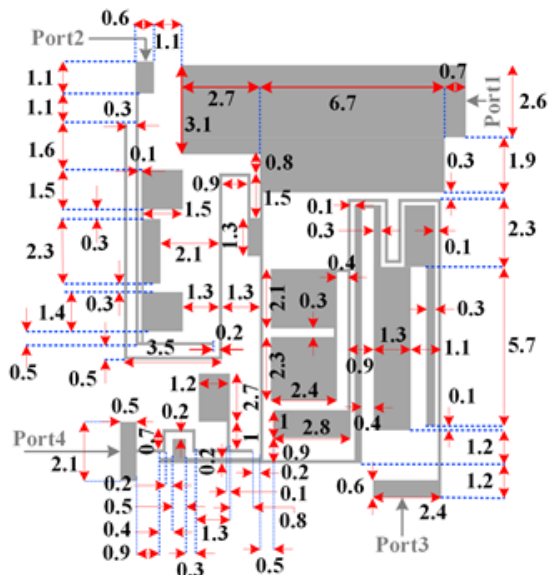

FIGURE 3. The layout of the proposed triplexer (unit: mm).

Fig.4 depicts the distribution of the current density of the designed triplexer for simulating port 2 (at 2.95 GHz), port 3 (at 1.4 GHz) and port 4 (at 4.4 GHz). As shown in Fig.4, the thin lines have high current densities. Therefore, tuning these lines is significant to improve the frequency response. As can be seen, by simulating port 2 at 2.95 GHz, the thin stub near this port shows high current density distribution. For port 3 at 1.4 GHz, the thin line connected to this port has a high current density. Accordingly, to improve the performance of the first channel we can change the dimensions of this physical length (l_2 in Fig.3). For simulating port 4, the loading effects of the other filters can be further investigated which can help to improve the performance of the last channel.

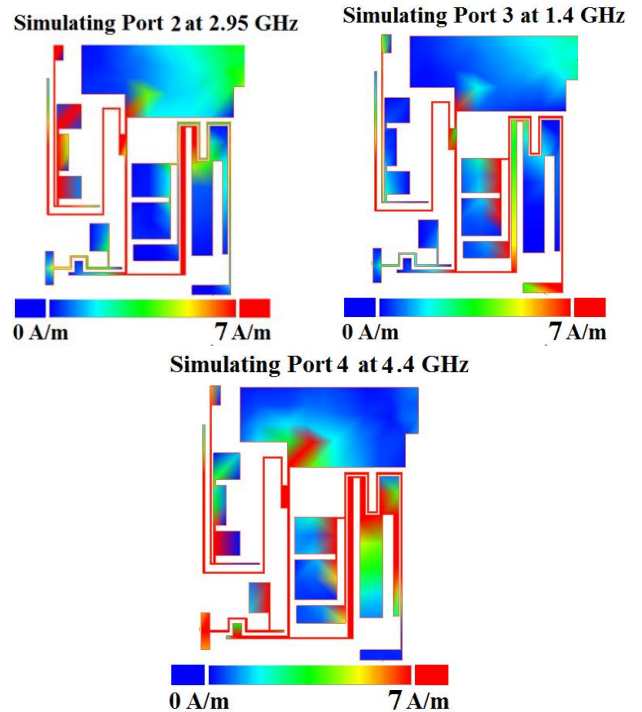

FIGURE 4. Current density distribution of the designed triplexer.

Fig.5 shows the frequency responses as function of the physical dimensions (w_1 , w_2 , l_1 , l_2 , w_3 and l_3). The results show that the middle, lower and upper channels are significantly affected by the lengths l_1 , l_2 and l_3 respectively. By decreasing the length l_1 , the middle channel will be broken. Reducing l_2 increases the level of harmonics. This is because, to remove the harmonic the length of the coupled lines must be increased. This issue is already proved theoretically and also confirmed in (10). Changing the widths has less effect on the frequency response than changing the lengths. This issue is verified by the current density distribution curves. Increasing w_1 and w_2 moves the 2nd and 1st channels to the left, which can help in miniaturization. However, increasing l_3 improves the selectivity of the last channel.

Fig.6 illustrates S_{11} as functions of these significant physical dimensions. The results show that decreasing l_1 and l_2 leads to an increase in the return loss. Meanwhile, decreasing w_2 improves return loss in the last channel which is due to having a positive loading effect of the BPFs. Increasing l_3 , destroys S_{11} in the last band. As can be seen, $l_3=3.7$ mm is the best choice to improve the return loss.

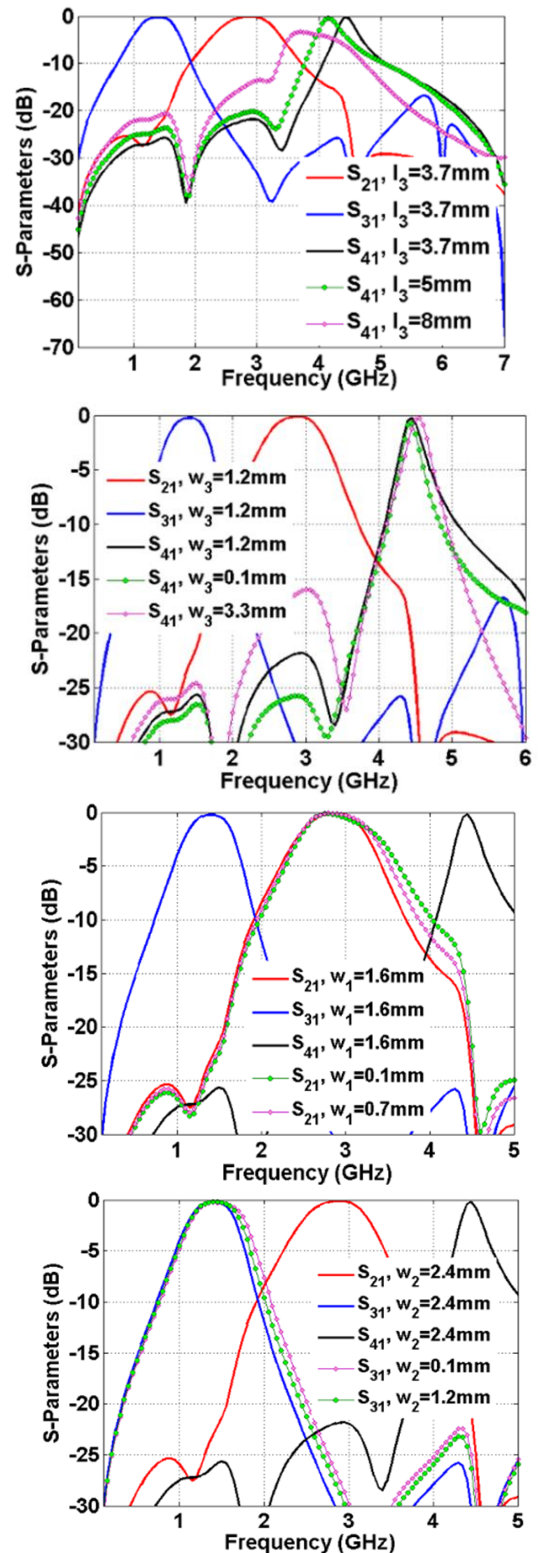
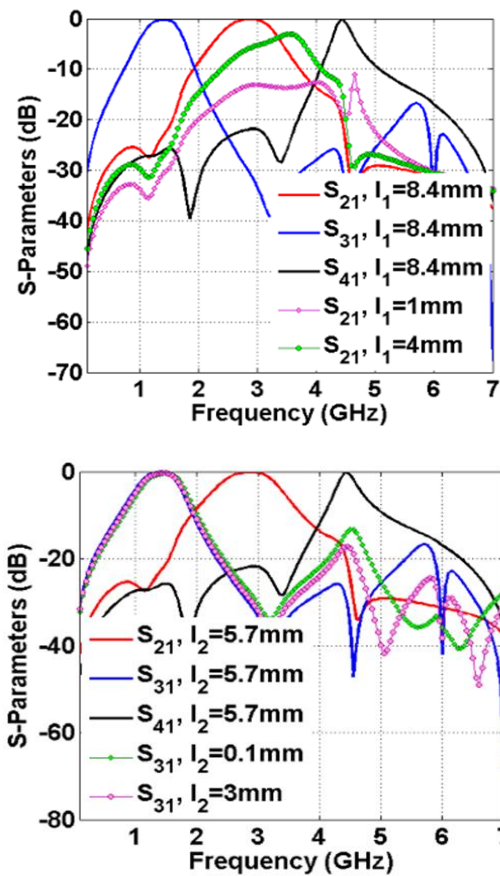

FIGURE 5. Frequency responses as functions of the significant physical dimensions.

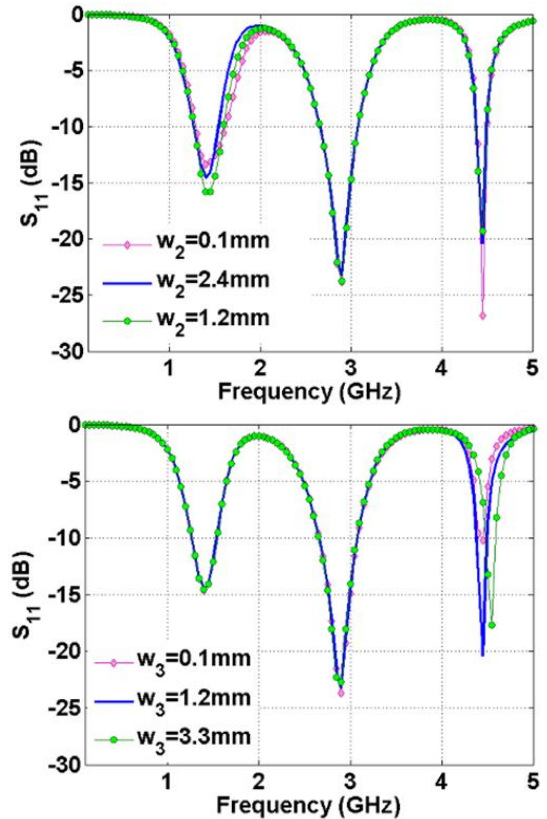
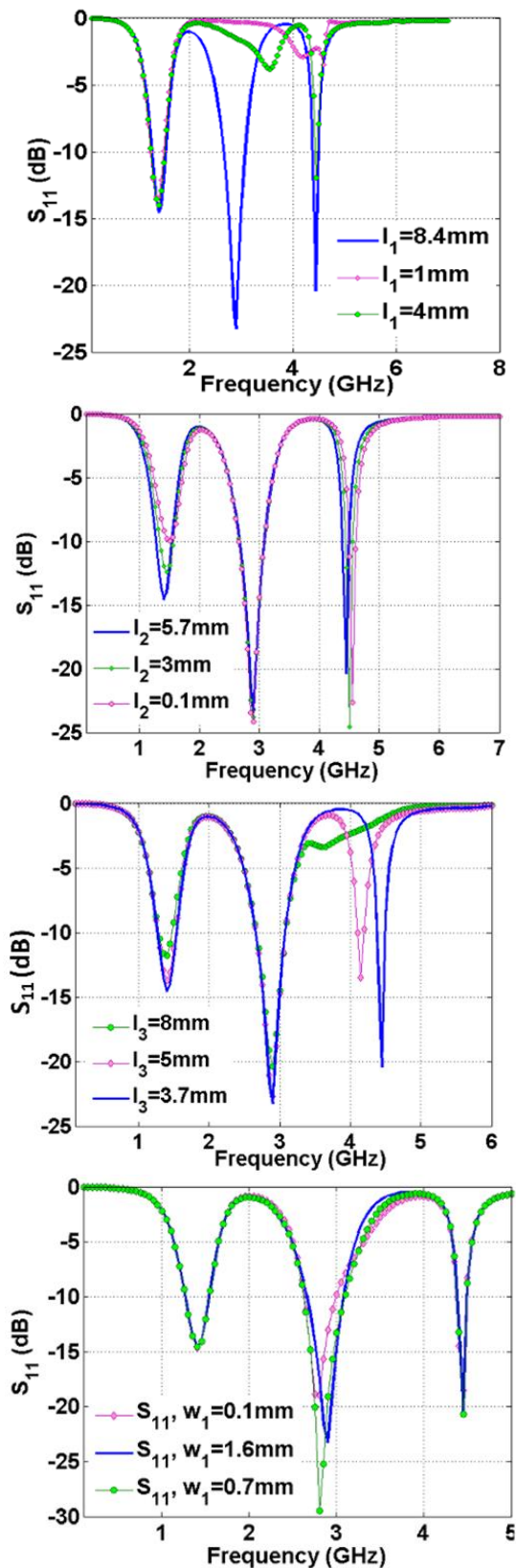

FIGURE 6. S_{11} as functions of the significant physical dimensions.

III. RESULTS AND DISCUSSIONS

We simulated and measured the designed microstrip triplexer using the EM simulator of ADS software and an HP8757A network analyzer, respectively. HP8757A network analyzer has the following features:

- Frequency ranges: 10 MHz-60 GHz
- Accurate swept power measurements (dBm)
- 40 dB directivity bridges
- Four input ports
- Four independent display channels
- Direct plotter or printer output

The substrate of the fabricated microstrip triplexer is RT/duroid 5880 ($h=0.7874$ mm, $\epsilon_r=2.22$ and $\tan(\delta)=0.0009$). The obtained measurement and simulation results of the transition parameters are depicted in Fig.7. The resonance frequencies are 1.4 GHz, 2.9 GHz and 4.4 GHz. The return losses and insertion losses are (15 dB and 0.19 dB) for the lower band, (25.2 dB and 0.08 dB) for the middle band and (32 dB and 0.19 dB) for the upper band. Since there are SMA and copper losses, the losses obtained by the simulations are smaller than the measurements. As can be seen, the channels are wide and flat, where the fractional bandwidths (FBW%) of the 1st, 2nd and 3rd channels are 49%, 34% and 7.2% respectively. The maximum harmonic level from DC up to 7.7 GHz is lower than -18 dB. There are several transition zeros at the stopband of all channels. Therefore, after the first channel, the 1st to 4th harmonics are suppressed. Fig.8

presents the obtained measured and simulated isolation between the output ports. The maximum levels of S_{23} , S_{24} and S_{34} are below -19 dB.

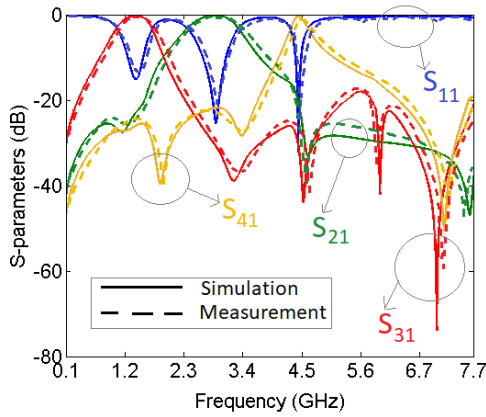

FIGURE 7. Transition parameters (simulated and measured).

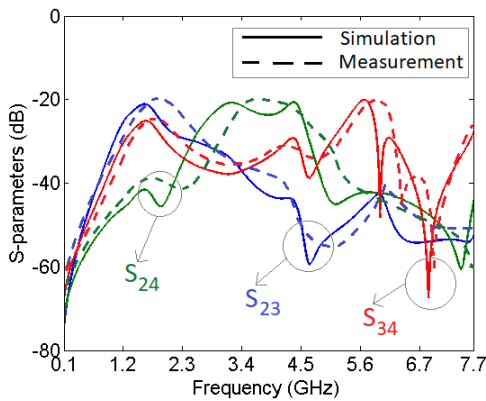

FIGURE 8. Isolations between the output ports (simulated and measured).

To verify the advantages of this work, we compared it with the previous triplexers in Table 1. In this table, the indexes 1 to 3 are related to the 1st to 3rd bands respectively. As shown in Table 1, our triplexer occupies the minimum area (0.007 λ_g^2) while we could not find a triplexer smaller than 0.01 λ_g^2 . Meanwhile, the best values of insertion loss (at all channels) and return loss (at the 2nd and 3rd channels) and the widest FBW (at the 1st and 2nd channels) are obtained in this work.

Another significant parameter in designing microstrip filtering devices is group delay, which is a type of distortion. It can change the shape of signals. Hence having a flat filtering passband with low group delay is an advantage. Despite this fact, most of the previous triplexers didn't pay attention to this issue. Because designing a triplexer is harder than diplexers and filters. The group delays of S_{21} , S_{31} and S_{41} in their corresponding passbands are shown in Fig.9. As can be seen, the maximum simulated group delays at the lower, middle and upper channels are 0.62 ns, 0.93 ns and 1.15 ns respectively which are very good values for a triplexer. Also, the measured group delays are better than 1.2 ns at all channels.

TABLE I
COMPARISON IN TERMS OF RESONANCE FREQUENCIES (F_{R1} , F_{R2} , F_{R3}), INSERTION LOSSES (IL_1 , IL_2 , IL_3), RETURN LOSSES (RL_1 , RL_2 , RL_3), FRACTIONAL BANDWIDTHS (Δ_1 , Δ_2 , Δ_3) AND SIZES (*: APPROXIMATED VALUES).

Refs	f_{r1}, f_{r2}, f_{r3} (GHz)	$IL_1,$ $IL_2,$ IL_3 (dB)	$RL_1,$ $RL_2,$ RL_3 (dB)	$\Delta_1, \Delta_2, \Delta_3$	Size (λ_g^2)
This Triplexer	1.4, 2.9, 4.4	0.19, 0.08, 0.19	15, 25.2, 32	49%, 34%, 7.2%	0.007
[5]	3.2, 3.7, 4.4	2.7, 2.5, 1.8	16, 16, 16	6.5%, 7%, 8%	0.048
[6]	1.4, 1.7, 1.9	3.4, 3.5, 3.6	---	4.96%, 4.57%, 4.82%	0.358
[7]	1.2, 1.8, 2.4	1.3, 1.3, 1.2	11.6, 14, 10	14.4%, 14%, 13.6%	0.055
[8]	3.3, 3.89, 4.56	2.2, 2.3, 2.3	Better than 14	---	0.275
[9]	0.9, 2.45, 5.35	0.37, 0.68, 0.4	11.8, 21.3, 13.8	---	0.088
[10]	1.5, 1.7, 1.9	4.9, 5.8, 5.95	---	3.3%, 2.9%, 3.6%	0.132
[11]	1.88, 2.1, 2.6	1.3, 2.3, 3.2	22, 25, 21	0.86%, 1.4%, 0.96%	0.1*
[12]	1, 1.25, 1.5	2.7, 1.8, 3.2	Better than 16	9.5%, 4.2%, 4.5%	0.064
[13]	2.67, 3.1, 3.43	0.72, 0.63, 0.71	24.5, 24, 24.7	---	0.137
[14]	1.4, 1.8, 3.2	0.1, 2, 1	25, 20, 20	5.2%, 2.8%, 9.4%	0.014
[15]	1.8, 3.2, 4.4	1.97, 1.99, 2.3	24, 22, 25	7.44%, 7.45%, 6.2%	0.177
[16]	2.4, 3.5, 5.8	0.9, 1.1, 1.3	---	6%, 4.5%, 3.6%	0.119
[17]	1.75, 2.35, 3.68	1.3, 1.4, 1.7	20, 25, 30	5.7%, 8.5%, 6.8%	0.027
[18]	1.45, 2.15, 2.75	3.6, 4.3, 4.8	15, 20, 15	6%, 6%, 4%	0.020
[19]	2.4, 3.5, 5.2	2.42, 1.62, 1.95	Better than 15	3%, 7%, 3%	0.164
[20]	2.3, 3.2, 3.6	0.78, 1.1, 0.62	19.8, 10, 28	5.2%, 5.5%, 1.6%	0.095
[21]	2.05, 2.45, 3.5	1.5, 1.8, 1.5	Better than 13	4.8%, 4%, 5.7%	0.346

We compared the measured group delays, types and the number of channels of our triplexer with the previous microstrip filtering devices in Table 2. As can be seen, compared to the previous works we could reduce this parameter significantly. Fig.10 illustrates a photograph of our triplexer. Compared to the previous works, we could obtain a triplexer with the most compact size, the minimum group delay and the lowest insertion losses. We used a new basic

microstrip structure to obtain the proposed triplexer. Also, we used a new mathematical analysis to find a method to get rid of harmonics and tune the resonance frequency. All results of the mathematical analysis, simulation and measurement confirm each other. The applications of the proposed triplexer may vary depending on the region and regulatory requirements. This triplexer can be used in the following applications:

Wi-Fi and Bluetooth, weather and military radars, some satellite communication systems and scientific research applications such as spectroscopy, medical imaging and plasma physics.

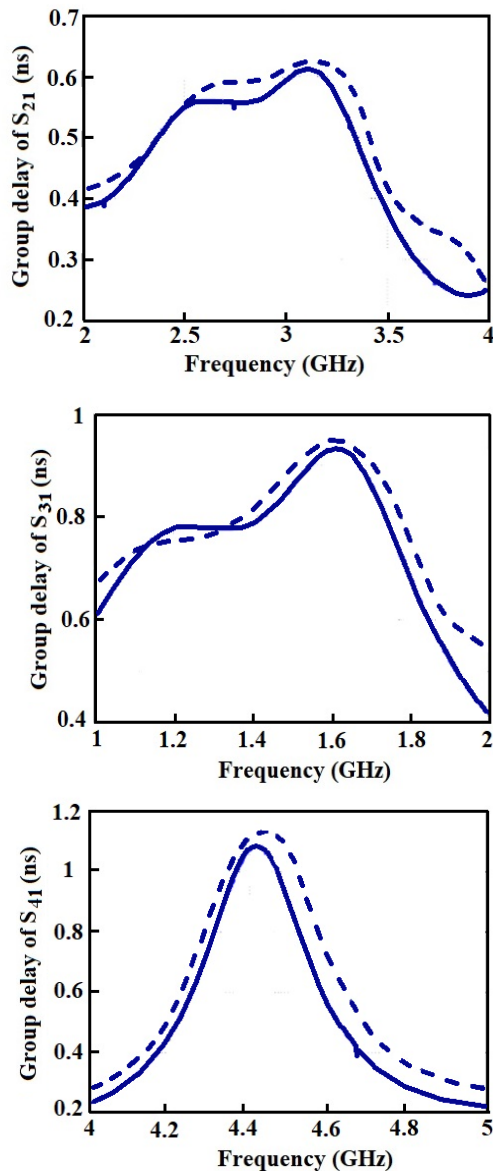

FIGURE 9. Simulated (solid lines) and measured (dashed lines) group delays of all channels.

TABLE II
COMPARISON IN TERMS OF GROUP DELAYS (GDS), TYPE AND THE NUMBER OF CHANNELS (NC).

Refs	NC	Type	Maximum GDs (ns)
This work	3	Triplexer	0.65, 0.95, 1.18
[25]	2	Diplexer	0.9, 1.1
[26]	4	Diplexer	2.76, 3.31, 0.91, 2.15
[27]	3	BPF	Better than 8ns at all channels
[28]	2	Diplexer	3, 3.14
[29]	3	BPF	3.67, 1.47, 0.83
[30]	2	Diplexer	3.15, 2.98
[31]	3	Triplexer	1.5, 6, 4.4
[32]	3	Triplexer	3, 3.1, 2.9



FIGURE 10. Fabricated triplexer.

IV. CONCLUSION

In this paper, a microstrip triplexer with a very compact size of $0.007\lambda_g^2$, flat channels, low group delays, low insertion losses (0.19/0.08/0.19 dB) and suppressed harmonics is designed, analyzed, fabricated and measured. It works at 1.4 GHz, 2.9 GHz and 4.4 GHz, which makes it suitable for 5G applications. The other advantage of this work is its wide channels, where the 1st and 2nd channels have the fractional bandwidths (FBW%) 49% and 34%, respectively. The proposed resonator is analyzed based on calculating the ABCD matrix and extracting S_{21} . To improve its performance, the designed triplexer is optimized. The comparison with the previous designs showed that our triplexer has the lowest insertion losses at all channels, the most compact size, the minimum group delays and the best return losses at the 2nd and 3rd channels.

ACKNOWLEDGMENT

The authors also gratefully acknowledge the funding support provided by the Universiti Teknologi Malaysia (UTM) under UTM Encouragement Research grant (20J65) and UTMSHine Batch 6 grant (09G97). This work also was partially supported by the Faculty of Engineering, Multimedia University, Cyberjaya (MMU).

REFERENCES

- [1] L. Nouri, S.I. Yahya and A. Rezaei, "Design and Fabrication of a Compact Branch-Line Hybrid Coupler with a Balanced Phase Using a New Microstrip Structure for GSM Applications," *AEU-International Journal of Electronics and Communications*, vol. 161, pp. 154529, 2023.
- [2] A. Rezaei, S. I. Yahya, "A New Design Approach for a Compact Microstrip Diplexer with Good Passband Characteristics", *ARO-The Scientific Journal of Koya University*, vol. 10, no. 2, pp. 1-6, 2022.
- [3] K.A. Majdi, Y.S. Mezaal, "New Miniature Narrow Band Microstrip Diplexer for Recent Wireless Communications", *Electronics*, vol. 12, pp. 716, 2023.
- [4] Y. Zhang, X. Tan, Q. Xiang, "A Compact Frequency- and Power-Dividing Ratio-Tunable Quadrature Coupler", *International Journal of RF and Microwave Computer-Aided Engineering*, vol. 2023, pp. 1-8, 2023.
- [5] J.Y. Wu, K.W. Hsu, Y.H. Tseng, W.H. Tu, "High-Isolation Microstrip Triplexer Using Multiple-Mode Resonators," *IEEE Microwave and Wireless Components Letters*, vol. 22, no. 4, pp.173-175, 2012.
- [6] P.H. Deng, M.L. Lai, S.K. Jeng and C.H. Chen, "Design of matching circuits for microstrip triplexers based on stepped impedance resonators," *IEEE Transactions on Microwave Theory and Techniques*, vol. 54, no. 12, pp. 4185-4192, 2006
- [7] X. Jin and Z. Yan, "Microstrip triplexer and switchable triplexer using new impedance matching circuits," *International Journal of RF and Microwave Computer-Aided Engineering*, pp.1-9, 2016.
- [8] C.W. Tang, M.G. Chen, "Packaged microstrip triplexer with star-junction topology," *Electronics Letters*, vol. 48, no. 12, pp. 699-701, 2012.
- [9] C. Zhu, J. Zhou and Y. Wang, "Design of microstrip planar triplexer for multimode/multi-band wireless systems," *Microwave Journal*, pp. 1-19, 2010.
- [10] S.C. Lin and C.Y. Yeh, "Design of Microstrip Triplexer with High Isolation Based on Parallel Coupled-Line Filters Using T-Shaped Short-Circuited Resonators," *IEEE Microwave and Wireless Components Letters*, vol. 25, no. 10, pp. 648-650, 2015.
- [11] A. El-Tokhy, R. Wu, Y. Wang, "Microstrip Triplexer using a common triple-mode resonator," *Microwave and Optical Technology Letters*, vol. 60, no. 7, pp. 1815-1820, 2018.
- [12] C.F. Chen, T.M. Shen, T.Y. Huang, R.B. Wu, "Design of Multimode Net-Type Resonators and Their Applications to Filters and Multiplexers," *IEEE Transactions on Microwave Theory and Techniques*, vol. 59, no. 4, pp. 848-856, 2011.
- [13] A. Rezaei and L. Noori, "Novel low-loss microstrip triplexer using coupled lines and step impedance cells for 4G and WiMAX applications," *Turkish Journal of Electrical Engineering & Computer Sciences*, vol. 26, pp. 1871-1880, 2018.
- [14] S. Keshavarz, A. Abdipour, A. Mohammadi, R. Keshavarz, "Design and implementation of low loss and compact microstrip triplexer using CSRR loaded coupled lines", *International Journal of Electronics and Communications (AEÜ)*, vol. 111, pp. 152913, 2019.
- [15] A. Chinig, A. Errkik, L. El Abdellaoui, A. Tajmouati, "Design of a Microstrip Diplexer and Triplexer Using Open Loop Resonators," *Journal of Microwaves, Optoelectronics and Electromagnetic Applications*, vol. 16, no. 2, pp. 65-80, 2016.
- [16] H.W. Wu, S.H. Huang, Y.F. Chen, "Compact microstrip triplexer based on coupled stepped impedance resonators," *IEEE MTT-S International Microwave Symposium Digest*, pp. 2-7, Seattle, WA, USA, 2013.
- [17] T. Yang, P.-L. Chi, T. Itoh, "Compact quarter-wave resonator and its applications to miniaturized diplexer and triplexer," *IEEE Transactions on Microwave Theory and Techniques*, vol. 59, no. 2, pp. 260-269, 2011.
- [18] T. Yang and G. Rebeiz, "A 1.26-3.3 GHz tunable triplexer with compact size and constant bandwidth," *IEEE Microwave and Wireless Components Letters*, vol. 26, no. 10, pp. 786-788, 2016.
- [19] J.F. Qian, F.C. Chen, "Wide stopband microstrip triplexer using common crossed, resonator and uniform impedance resonator," *Progress in Electromagnetics Research Letters*, vol. 69, pp. 79-86, 2017.
- [20] A. Rezaei, S.I. Yahya and L. Nouri, M.-H. Jamaluddin, "Design and fabrication of a compact microstrip triplexer for wimax and wireless applications," *Engineering Review*, vol. 41, no. 1, pp. 85-91, 2020.
- [21] T. Sugchai, I. Nattapong and C. Apirun, "Design of Microstrip Triplexer Using Common Dual-mode Resonator with Multi-Spurious Mode Suppression for Multiband Applications," *Applied Mechanics and Materials*, vol. 763, pp.182-188, 2015.
- [22] L. Zhou, Z. Long, Q. Feng, Q. Jin, Y. Li, "Channel-Continuous Triplexer With Multiple Transmission Zeros Based on Cascaded High-Pass and Low-Pass Filters", *IEEE Microwave and Wireless Components Letters*, vol. 32, no. 5, pp. 395 - 398, 2022.
- [23] M. Jamshidi, S.I. Yahya, L. Nouri, H.H. Dezaki, A. Rezaei, M.A. Chaudhary, "A Super-Efficient GSM Triplexer for 5G-Enabled IoT in Sustainable Smart Grid Edge Computing and the Metaverse", *Sensors*, vol. 23, no. 7, pp. 3775, 2023.
- [24] J.S. Hong and M.J. Lancaster, "Microstrip Filters for RF/Microwave Applications," *John Wiley & Sons*, 2001.
- [25] S.I. Yahya, A. Rezaei, L. Nouri, "Compact wide stopband microstrip diplexer with flat channels for WiMAX and wireless applications," *IET Circuits, Devices & Systems*, vol. 14, no. 6, pp. 846-852, 2020.
- [26] S.I. Yahya, L. Nouri, "A low-loss four-channel microstrip diplexer for wideband multi-service wireless applications," *AEU-International Journal of Electronics and Communications*, vol. 133, pp. 153670, 2021.
- [27] Y. Liu, "A tri-band bandpass filter realized using tri-mode T-shape branches," *Progress In Electromagnetics Research*, vol. 105, pp. 425-44, 2010.
- [28] A. Rezaei, L. Noori, "Compact low-loss microstrip diplexer using novel engraved semi-patch cells for GSM and WLAN applications," *AEU-International Journal of Electronics and Communications*, vol. 87, pp. 158-63, 2018.
- [29] G. Wibisono, T. Firmansyah, T. Syafraditya, "Design of triple-band bandpass filter using cascade tri-section stepped impedance resonators," *Journal of ICT Research and Applications*, vol. 10, no. 1, pp. 43-56, 2016.
- [30] L. Noori, A. Rezaei, "Design of a microstrip diplexer with a novel structure for WiMAX and wireless applications," *AEU-International Journal of Electronics and Communications*, vol. 77, pp.18-22, 2017.
- [31] F.-C. Chen, J.-M. Qiu, H.-T. Hu, Q.-X. Chu and M. J. Lancaster, "Design of Microstrip Lowpass-Bandpass Triplexer With High Isolation," *IEEE Microwave and Wireless Components Letters*, vol. 25, no. 12, pp. 805-807, 2015.
- [32] M. Karlsson, P. Hakansson and S. Gong, "A Frequency Triplexer for Ultra-Wideband Systems Utilizing Combined Broadside- and Edge-Coupled Filters," *IEEE Transactions on Advanced Packaging*, vol. 31, no. 4, pp. 794-801, 2008.



LEILA NOURI received her B.Sc. and M.Sc. degrees in electronic engineering from Razi University, Kermanshah, Iran in 2005 and 2009 respectively. She received her Ph.D. in electronic engineering at the Shiraz University of Technology. She is the author of one books, more than 60 articles, and more than 5 research and industrial projects. Her research interests focus on microstrip coupler, microstrip filter, neural networks and LNAs.



FARID ZUBIR (Member, IEEE) received the B.Eng. degree in electrical (majoring in telecommunication) and the M.Eng. degree in RF and microwave from Universiti Teknologi Malaysia (UTM), in 2008 and 2010, respectively, and the Ph.D. degree from the University of Birmingham, U.K., in 2016, for research into direct integration of power amplifiers with antennas in microwave transmitters. He currently serves as an Assistant Professor and Research Fellow at Department of Communication Engineering, School of Electrical

Engineering, and Wireless Communication Centre, UTM, respectively. He was an Honorary Postdoctoral Research Fellow from Sept. 2019 until Aug. 2021 at The University of British Columbia (UBCO), Okanagan, BC, Canada, where he was conducting research into highly efficient and linear amplification power amplifier topology for wireless power systems. His research interests and specialization include the area of RF and microwave technologies, including linearization and high-efficiency techniques for PAs, beamforming networks, planar array antenna, dielectric resonator antenna (DRA), and active integrated antenna (AIA).



SALAH I. YAHYA is a Professor (Full), joined the department of Software Engineering at Koya University in 2010. He has a B.Sc. degree in Electrical Engineering, an M.Sc. degree in Electronics and Communication Engineering and a Ph.D. degree in Communication and Microwave Engineering. He is a consultant engineer and a senior member of the IEEE-USA and AMTA-USA. Prof. Yahya has many published research articles in high quality journals and he presented many conference papers. His current research interests include antenna design, numerical RF dosimetry, MW measurement and MW components design. Prof. Yahya is a regular reviewer of the Electromagnetics Academy, Cambridge, USA, PIERS Journals publications, since 2009, Science and Engineering of Composite Materials journal and International Journal of Applied Electromagnetics and Mechanics.



ABBAS REZAEI is an Associate professor of Electrical Engineering in Kermanshah University of Technology. He was born in Kermanshah, Iran in 1982. He received the BSe, MSe and PhD in electronics engineering from Razi University, Kermanshah, Iran, in 2005, 2009 and 2013, respectively. He is the author of two books, more than 100 articles, and more than 10 research and industrial projects. His current research interests include RF and microwave circuits and computational intelligence.



FAWWAZ HAZZAZI was born in Kharj, a region of the Saudi Arabian province of Riyadh. He completed his Bachelor of Science (B.S.) in Electrical engineering at the Prince Sattam Bin Abdulaziz University-affiliated College of Engineering in Kharj, Saudi Arabia. He earned an M.S. in Electrical and Computer Engineering from the University of Maine in Orono, United States. He completed his Ph.D. in Electrical Engineering at Louisiana State University in Baton Rouge, Louisiana, United States. He has both industry and academic experience. His current research focuses on the characterization and fabrication of nanomaterials for the production of nanoscale electronic applications, electronic sensors of the next generation.



MAHER ASSAAD received the Master degree in electrical engineering/microelectronics IC design from the University of Montreal, Montreal, Canada, in 2002, and the Ph.D. degree in electrical engineering/microelectronics IC design from the University of Glasgow, Glasgow, U.K., in 2009. He was a Senior Lecturer of electrical engineering with the University Technology of PETRONAS, Malaysia, and an Associate Professor of electronic and communication engineering with the

American University of Ras Al Khaimah in the UAE. He is currently a Professor of electrical and computer engineering with Ajman University, United Arab Emirates. His research interests include the design of circuits/integrated circuits for various type of sensors and for wireline and optical communication systems.



MUHAMMAD AKMAL CHAUDHARY (Senior Member, IEEE) received the master's and Ph.D. degrees in electrical and electronic engineering from Cardiff University, Cardiff, U.K., in 2007 and 2011, respectively, and the M.B.A. degree in leadership and corporate governance from the Edinburgh Business School, Heriot-Watt University, Edinburgh, U.K., in 2022. Before joining Ajman University, United Arab Emirates, in 2012, he held a Postdoctoral Research position with the Centre for High-Frequency

Engineering, Cardiff University. He is currently an Associate Professor of electrical engineering at Ajman University. His research interests include nonlinear device characterization, spectrum-efficient power amplifiers, nonlinear measurement techniques, and microwave electronics have resulted in over 100 academic articles. Dr. Chaudhary is a Chartered Engineer of the Engineering Council, U.K., and a fellow of the Higher Education Academy, U.K.



ZUBAIDA YUSOFF (Member, IEEE) holds the position of a Senior Lecturer at the Faculty of Engineering, Multimedia University. She received her B.Sc. in Electrical and Computer Engineering (cum laude with distinction) and M.Sc. in Electrical Engineering from The Ohio State University, USA in 2000 and 2002 respectively. She worked with Telekom Malaysia International Network Operation in 2002 before she joined Multimedia University in 2004. She continued her studies at Cardiff University, Wales, UK in 2008 and received

Ph.D degree in 2012. She has presented technical papers at conference nationally and internationally. One of her conference papers has received "Honorable Mention" for the Student Paper Competition at the International Microwave Symposium, USA in 2011. She has authored/co-authored more than 50 journals and conference papers. Her teaching and research focus in

the area of Power Amplifier Design, Antenna, 5G Communications and Analog/Mixed Signal RF Circuit Design.



B.N. Nhu (Binh Nguyen Le) is a dedicated researcher and academic in the field of Engineering. She obtained her B.Sc. and M.Sc. degrees in Engineering from Da Nang University of Technology in 2011 and 2016, respectively. She is pursuing her Ph.D. in Engineering, further expanding her knowledge and expertise in the field. As a member of the Research and Development Institute at Duy Tan University, Le Nhu Binh actively contributes to the advancement of knowledge and innovation in engineering. Her research focuses on the

applications of artificial intelligence in engineering, as well as exploring sustainable solutions in the field of engineering.