

Grounded Generalized Impedance Converter Based on Differential Voltage Current Conveyor (DVCC) and its Applications

Amira R. Hamad and Muhammed A. Ibrahim

Published in :

OUTLINE

- **Introduction & Literature Survey**
 - **Circuit description**
 - **Simulation results**
 - **Application Circuits**
 - **Conclusion**
- 

Introduction & Literature Survey

- The inductor is a passive component which is used in the implementation of various electronics circuits for different applications.
 - However the use of a physical inductor poses many problems. One common problem among them is that physical inductors are large in size and have too many numbers of turns which makes it impossible to realize practically.
- 

Introduction & Literature Survey (Cont'd)

- Therefore, frequency-dependent negative resistor (FDNR) element was introduced by Bruton and used in the realization of ladder filters.
 - By using this element the ladder filters has eliminated the floating inductance while creating a grounded FDNR element.
- 

Introduction & Literature Survey (Cont'd)

- Formerly utilized operational amplifiers (op-amps) are currently replaced by other active elements.
 - One reason is the fact that in some cases the op-amps –based impedance converters have a rather complicated topology and that their operation is based on fulfilling several relations among the parameters of passive elements.
- 

Introduction & Literature Survey (Cont'd)

- From this point of view, Differential Voltage Current Conveyors (DVCC) appears to be more advantageous active elements for implementing the impedance converters.
- The DVCC has the advantages of both of the second generation current conveyor (CCII) such as large signal bandwidth, great linearity, wide dynamic range and differential difference amplifier (DDA) such as arithmetic operation capability, non-inverting and inverting output currents simultaneously (Alam, 2014).

Introduction & Literature Survey (Cont'd)

A close investigation of the literature reveals that the proposed circuits given in (Gupta et al., 2013, Soliman 2012, Khan et al. 2002, Jaikla and Siripruchyanan 2006, Ibrahim et al. 2012, Khan et al. 2003, Siddikee and Parveen 2015) suffer from one or more of the following weaknesses:



Introduction & Literature Survey (Cont'd)

- Excessive number of passive components (four or more) as in (Gupta et al. 2013, Soliman 2012, Khan et al., 2002).
- Excessive number of active elements (three or more) which enlarge the chip area as in (Gupta et al. 2013, Soliman, 2012).
- Providing only grounded inductance simulator and the grounded FDNR cannot be realized as in (Jaikla and Siripruchyanan 2006, Ibrahim et al. , 2012).
- Use of floating passive components as in (Khan et al. 2003, Ibrahim et al. 2012, Gupta et al. 2013).
- Use of different kinds of active components as in (Khan et al. 2003, Soliman 2012, Jaikla and Siripruchyanan 2006, Gupta et al. 2013, Siddikee and Parveen 2015).

Introduction & Literature Survey (Cont'd)

- The purpose of this paper is to propose a topology of realization of grounded generalized impedance converter (GIC).
- The proposed GIC can also be used in the realization of grounded inductor or FDNR elements.
- The proposed topology consists of a pair of DVCC and three grounded passive elements, which makes it suitable for integrated circuit implementation.
- The circuit offers attractive features, such as there is no need to another type active building block, independent tuning of quality factor and central frequency, all grounded passive components, and low passive sensitivities

Introduction & Literature Survey (Cont'd)

- To confirm the usability of the proposed topology, the GIC is used to realize grounded FDNR simulator that is used to make a RLC Bandpass (BP) filters.
 - In addition, it is used to realize grounded inductance simulator that is used to make a parallel resonant circuit, and generating Hartley oscillator
- 

Circuit Description

$$\begin{bmatrix} I_{Y1} \\ I_{Y2} \\ V_X \\ I_{Z+} \end{bmatrix} = \begin{bmatrix} 0 & 0 & 0 & 0 \\ 0 & 0 & 0 & 0 \\ 1 & -1 & 0 & 0 \\ 0 & 0 & 1 & 0 \end{bmatrix} \begin{bmatrix} V_{Y1} \\ V_{Y2} \\ I_X \\ V_{Z+} \end{bmatrix}$$

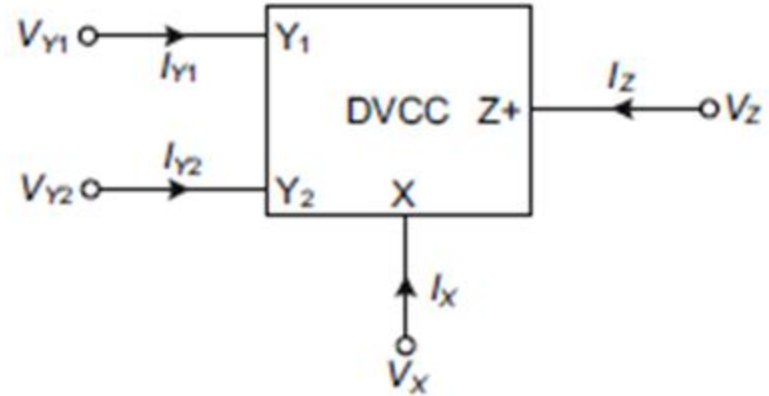

Fig. 1 Electrical symbol of the DVCC+

Circuit Description (Cont'd)

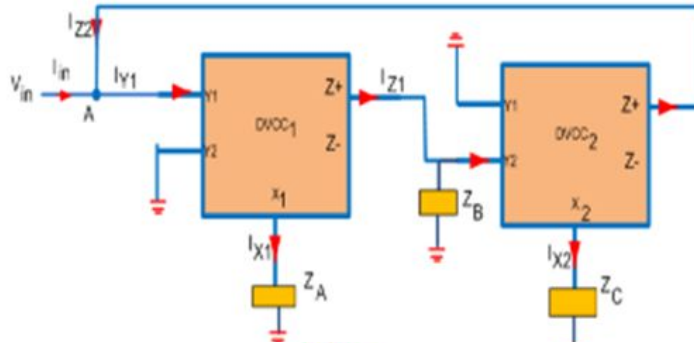

Fig. 2: the proposed grounded GIC

$$Z_{in} = \frac{V_{in}}{I_{in}}$$

$$I_{in} + I_{Z2} = I_{y1}, I_{in} = -I_{Z2} \dots$$

$$I_{X2} = \frac{V_{X2}}{Z_C} = \frac{V_{Y12} - V_{Y22}}{Z_C} = \frac{-V_{Y22}}{Z_C} \dots$$

$$V_{Y22} = V_{Z1} = I_{Z1}Z_B = I_{X1}Z_B \dots$$

$$I_{X1} = \frac{V_{Y11} - V_{Y21}}{Z_A} = \frac{V_{in}}{Z_A} \dots$$

$$Z_{in} = \frac{Z_A Z_C}{Z_B}$$

Circuit Description (Cont'd)

□ If Z_A and Z_C are selected as resistors R_A and R_C respectively and Z_B is selected as capacitor C_B and by substituting them in the previous equation then the input impedance can be obtained as

$$Z_{in}(s) = sR_A R_C C_B = s L_{eq.}$$

$$L_{eq.} = R_A R_C C_B$$

Setting $R_A = R_C = R$ we get :

$$L_{eq.} = R^2 C_B$$

Circuit Description (Cont'd)

□ If Z_A and Z_C are selected as capacitors C_A and C_C respectively and Z_B is selected as resistor R_B and by substituting them in the previous equation then the input impedance can be obtained an FDNR as

$$Z_{in}(s) = \frac{1}{s^2 C_A C_C R_B} = \frac{1}{s^2 D_{eq}}$$

$$D_{eq} = C_A C_C R_B .$$

Setting $C_A = C_C = C$ we get :

$$Z_{in}(j\omega) = \frac{1}{s^2 C^2 R_B} = \frac{-1}{\omega^2 C^2 R_B}$$

Simulation Results

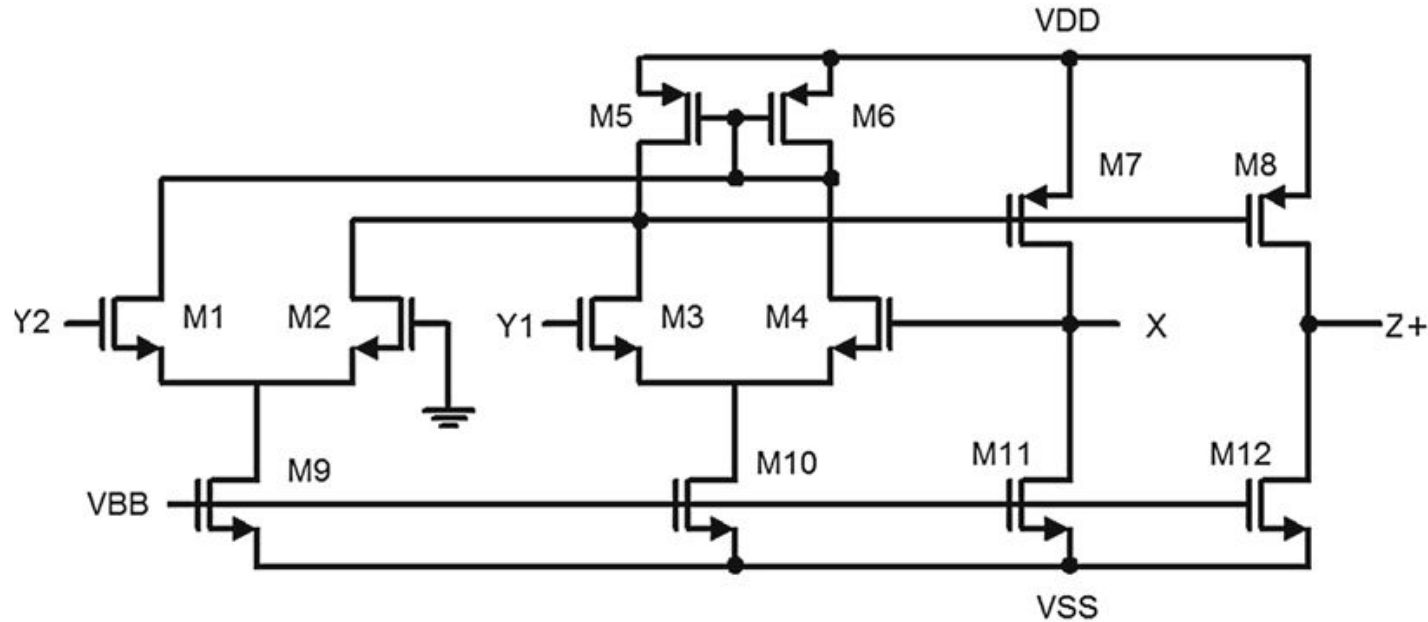

Fig. 3 The CMOS implementation of the DVCC+

Simulation Results (Cont'd)

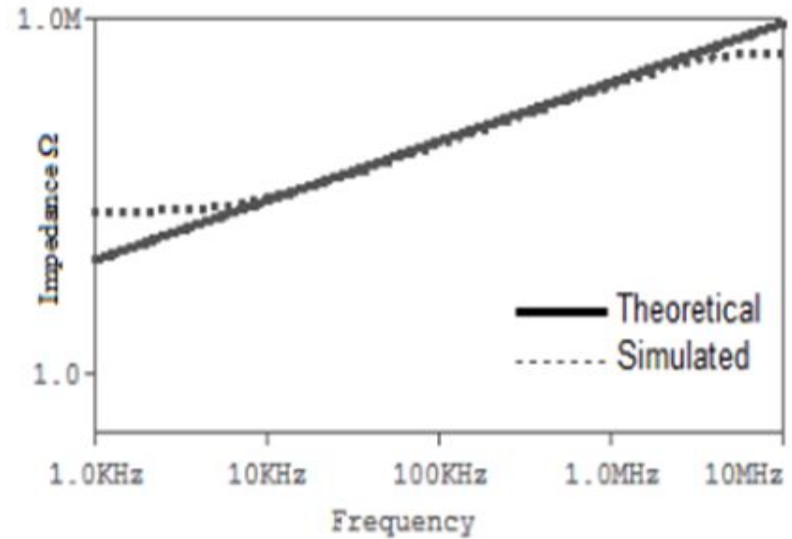
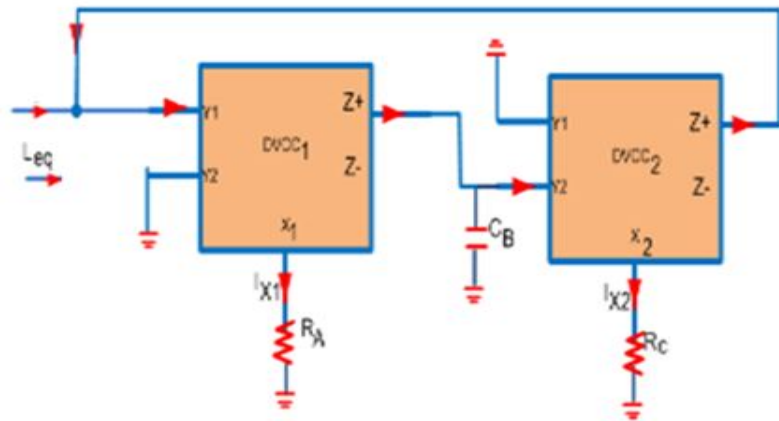

Fig.4 grounded GIC Circuit and its simulation results

Simulation Results (Cont'd)

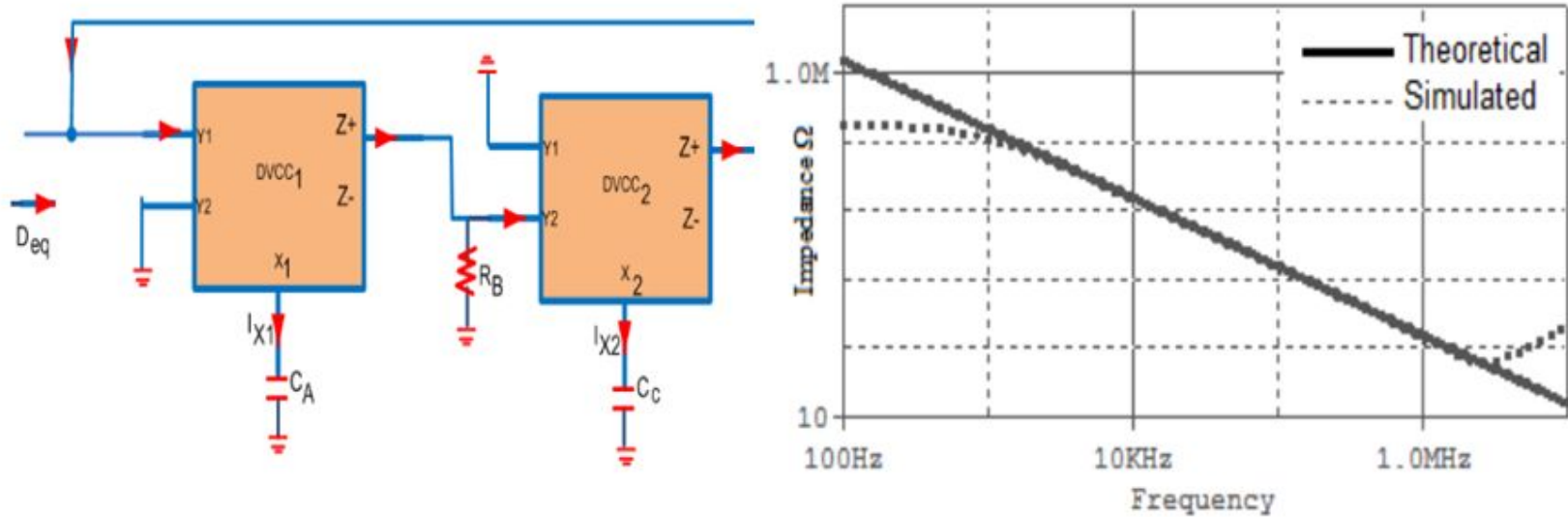

Fig. 5 grounded FDNR Circuit and its simulation results

Simulation Results (Cont'd)

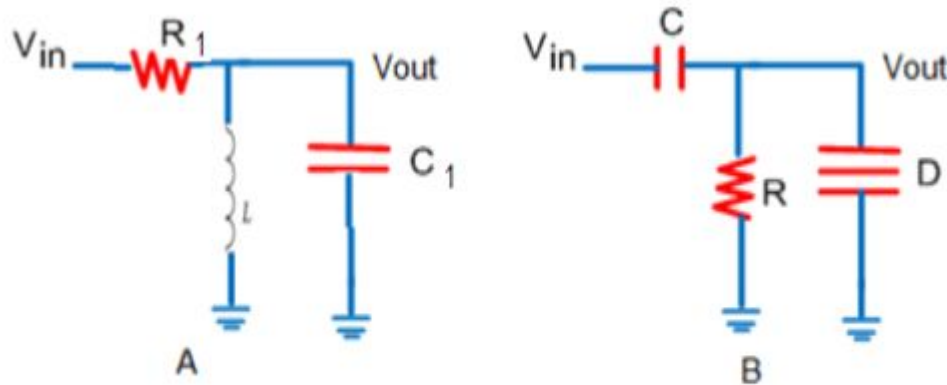
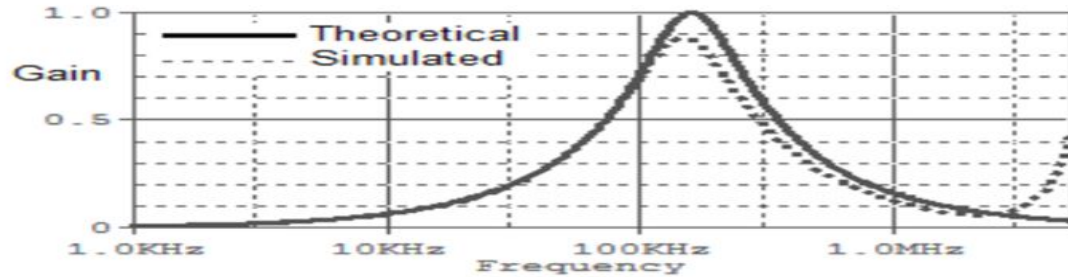

Fig. 6: (a) BP filter with RLC, (b) Transformed BP filter with FDNR

Simulation Results (Cont'd)



(a)

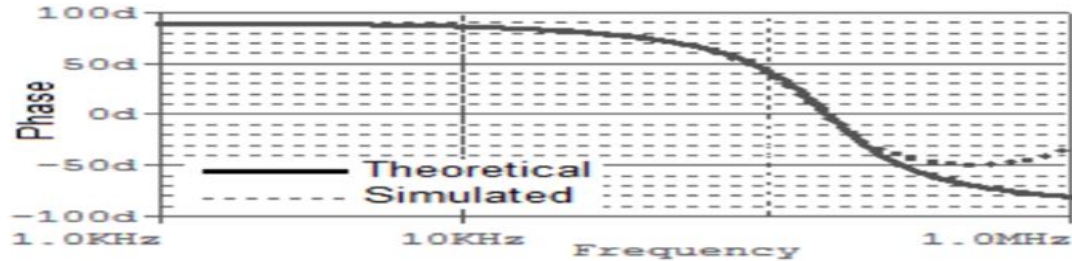
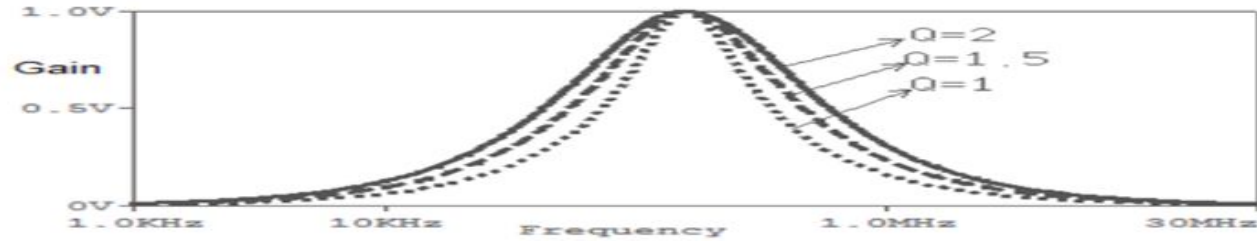
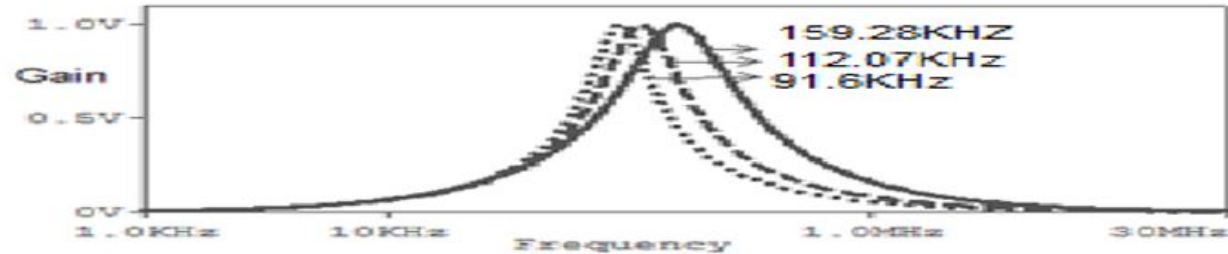

Fig. 7: (a) Gain response, (b) Phase response of the theoretical and simulated BP filter in Fig. 6b

Simulation Results (Cont'd)



(a)



(b)

Fig. 8: The magnitude responses of the BP filter (a) for different values of Q (b) for different values of center frequency

Simulation Results (Cont'd)

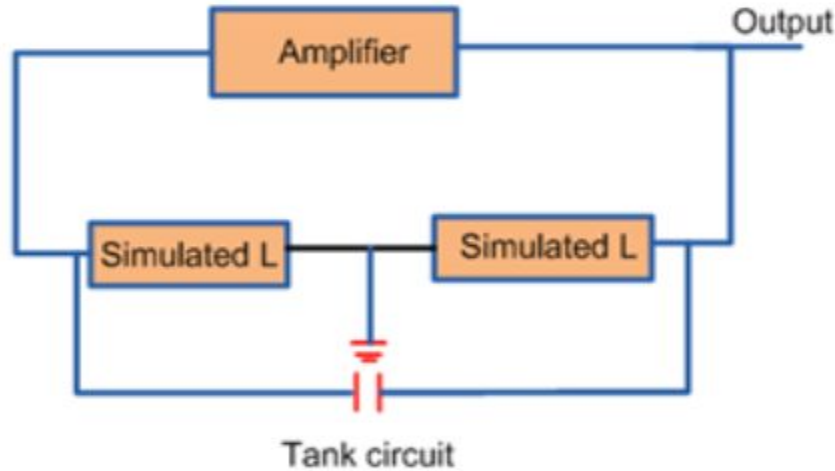

(a)

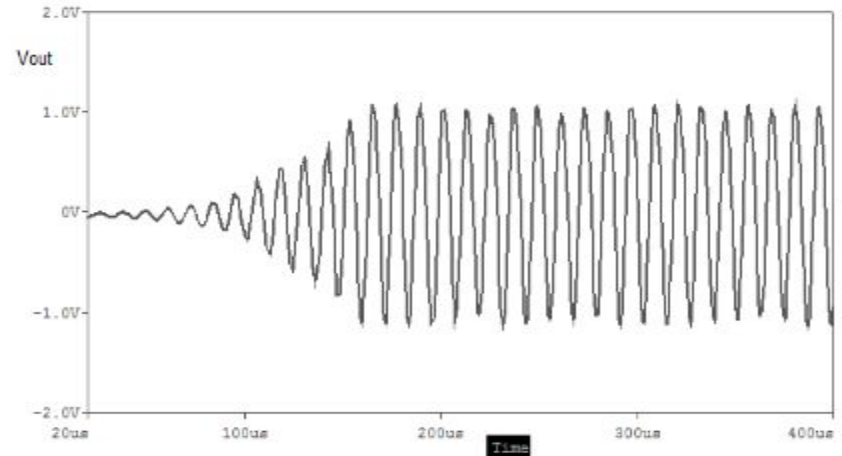

(b)

Fig. 9: (a) general circuit diagram of the LC Hartley oscillator (b) output response

Simulation Results (Cont'd)

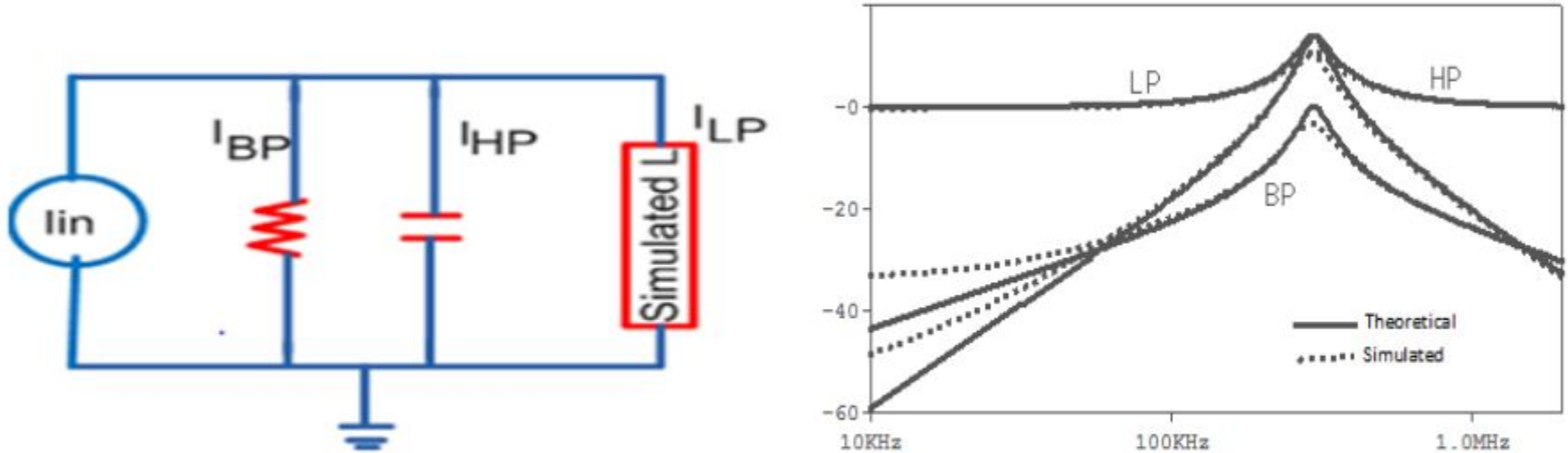

Fig. 10: parallel resonant circuit used for simulation and its gain responses

Conclusion

- Grounded GIC based on differential DVCCs as active elements has been proposed.
- Only two DVCCs and three grounded passive elements were used to achieve the grounded GIC.
- This makes the proposed topology more suitable for integrated circuit fabrication.
- Moreover, it provides attractive features, such as there is no need to alternative type of active building blocks, employment of all grounded passive elements, free tuning of quality factor and central frequency, and low passive sensitivities.

Conclusion (Cont'd)

- To demonstrate the validity of the proposed grounded GIC some applications are included.
- The PSPICE simulation results agree well with the theoretical analysis.





Thank You

Questions?