



Kurdistan Region – Iraq  
Cihan University  
Communication & Computer  
Engineering Department

***INCREASE YOUR KNOWLEDGE BY  
USING YOUR SMART PHONE***



2017 – 2018

Asst. Lecturer

**ADIL HUSSEIN MOHAMMED**

رَبِّ زِدْنِي عِلْمًا

"O my Lord!

Increase me in  
my knowledge!"

QUR'AN 20:114

اللَّهُمَّ إِنِّي أَسْأَلُكَ عِلْمًا نَافِعًا

"O Allah!

I ask You  
for knowledge  
that is of benefit"

Knowledge is  
Power

# STEPHEN HAWKING

Knowledge is  
Power

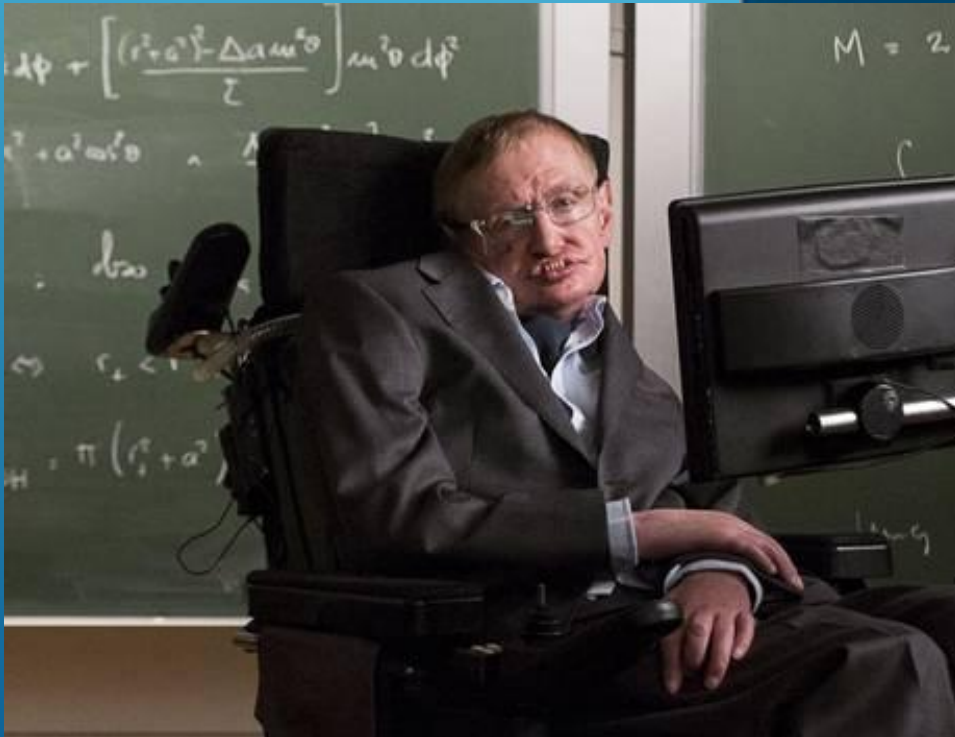

ITMES      HELP ?      DESIGN      TOOLS      BLOCK  
NOTES      SYSTEMS      FORMULA      ANALYSIS      DAIGRAM  
EQUATIONS      UNITS      CONDITIONS      SKILL  
CIRCUITS      CALCULATION      TIME      MEASUREMENTS  
FIGURES      LECTURES      REFERENCES  
PROBLEMS      EXAMINATION  
EXPRESSION      SIMULATION  
EVALUATION



# How do you spend your boring time ?

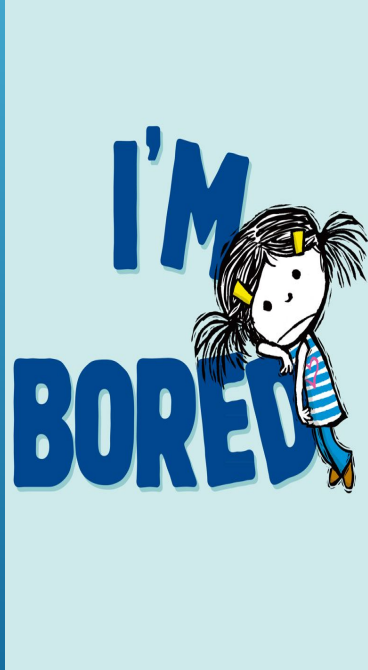

# Games in your phone !!!!!

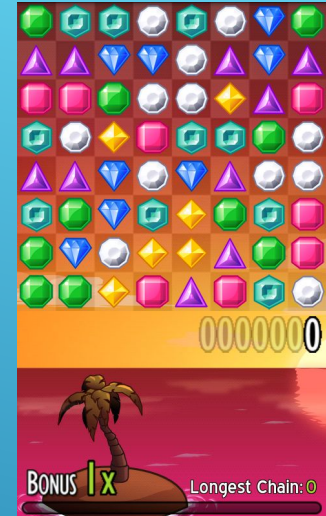

# MOBILE APPLICATION

A mobile application is a software application designed to run on mobile devices such as smartphones and tablet computers.



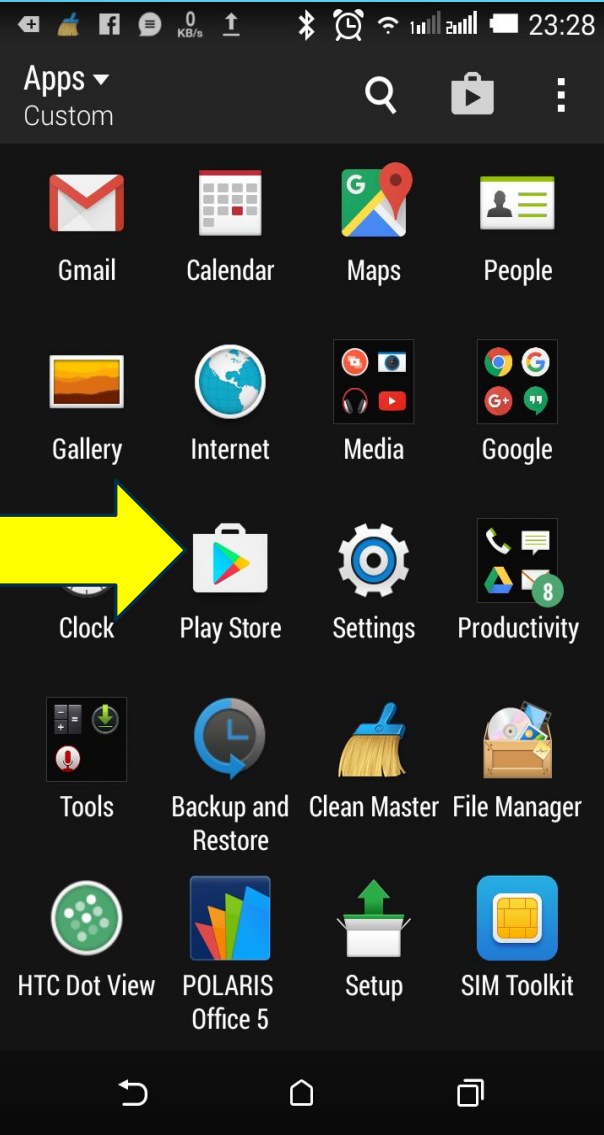

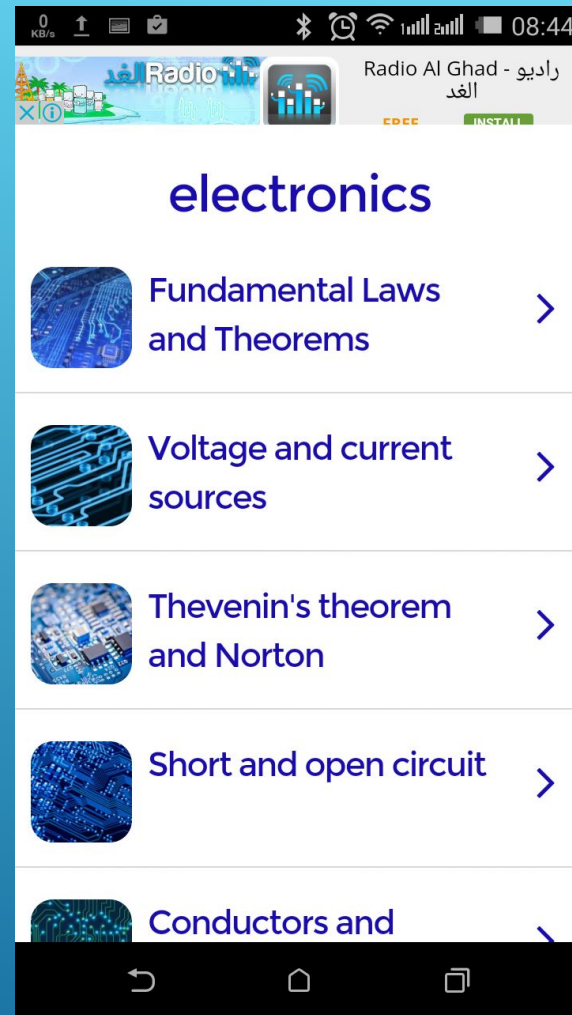
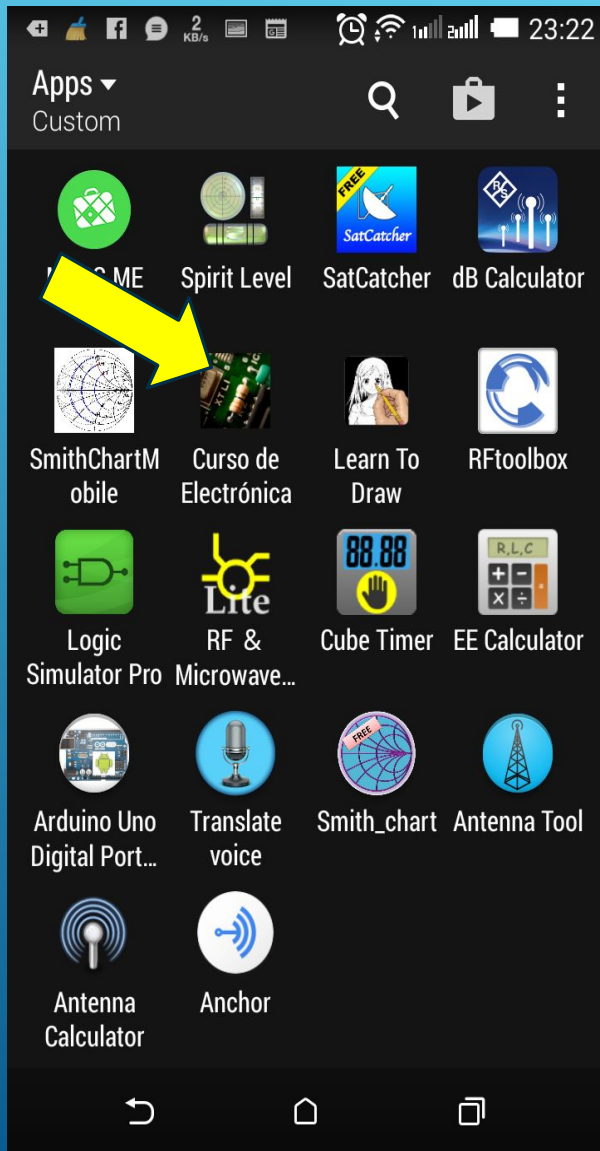

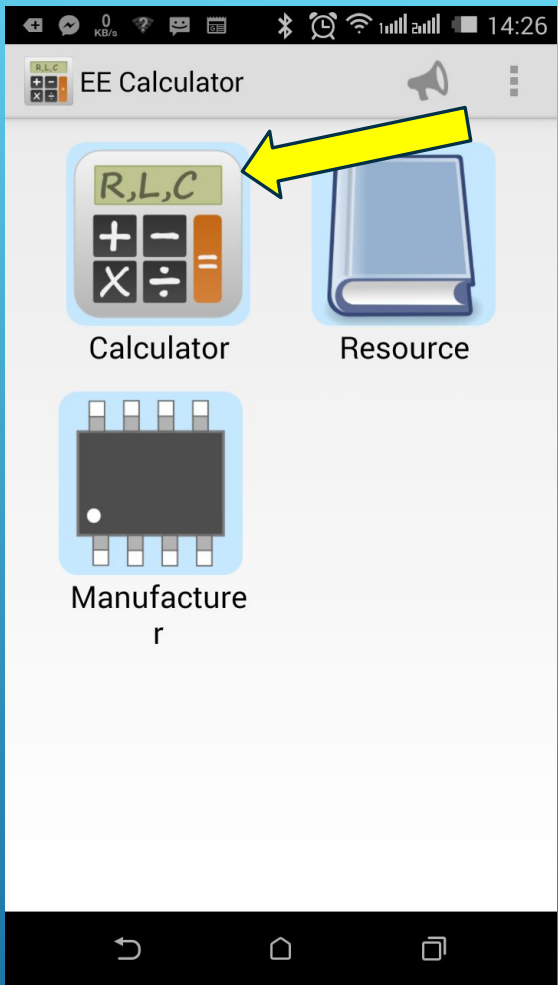
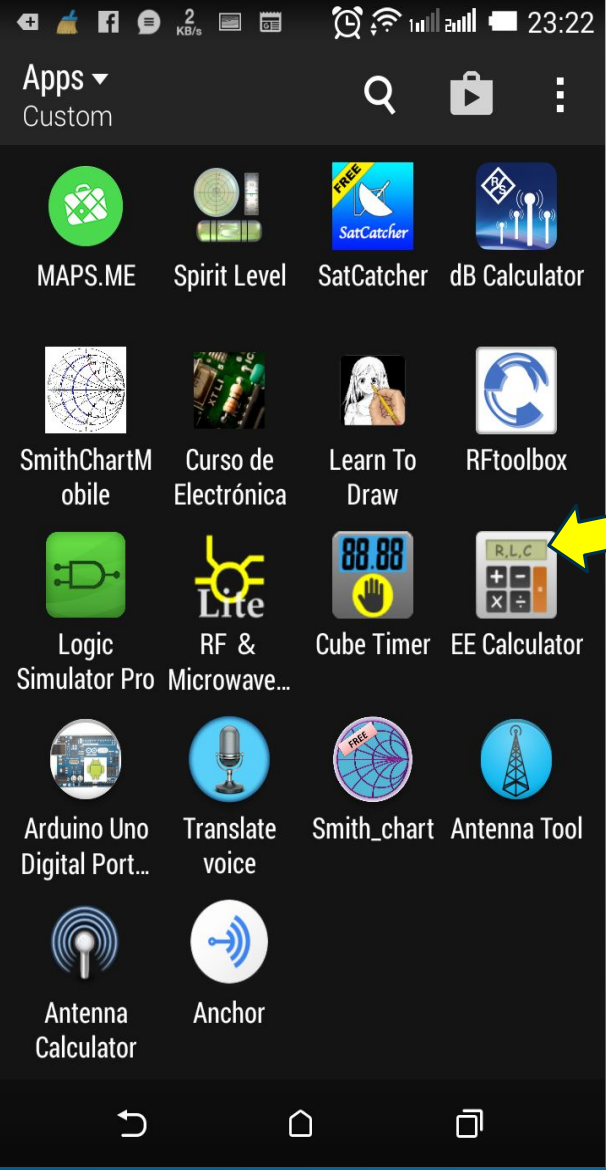

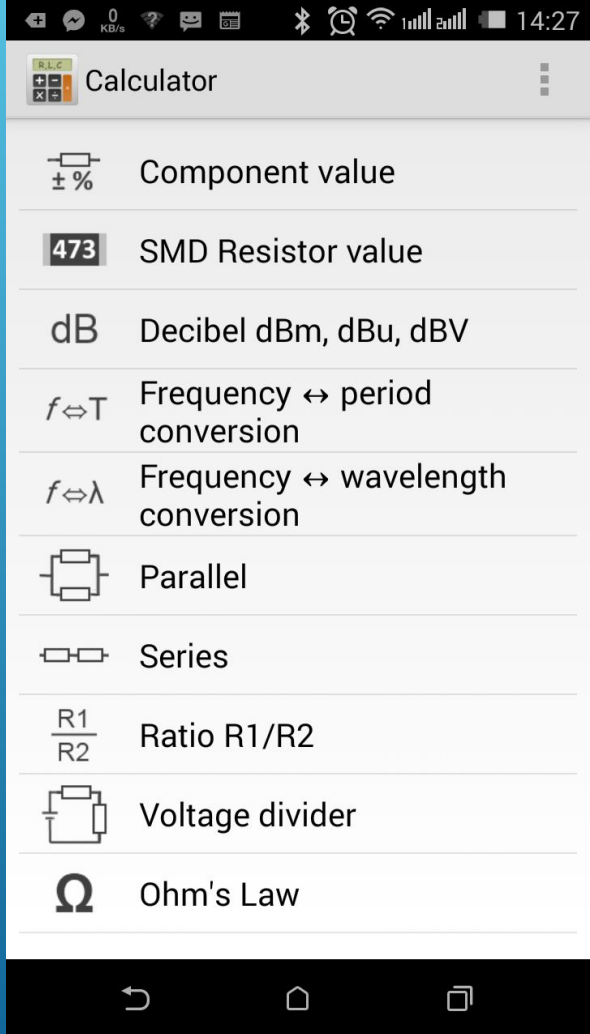

RC Circuit - Filter

LPF    HPF    Cutoff

Low-pass filter

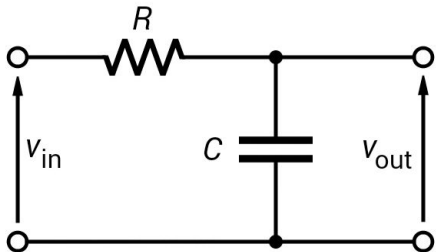

Cutoff Frequency  $f_c$ ,

$$f_c = \frac{1}{2\pi RC}$$

$$\omega_c = 2\pi f_c = \frac{1}{RC}$$

Gain (dB)

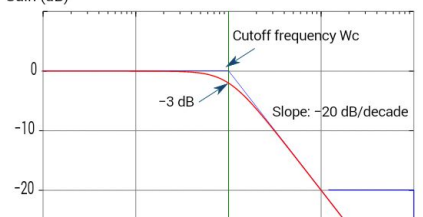

RC Circuit - Filter

LPF    HPF    Cutoff



Cutoff Frequency  $f_c$ ,

$$f_c = \frac{1}{2\pi RC}$$

$$\omega_c = 2\pi f_c = \frac{1}{RC}$$

Gain (dB)

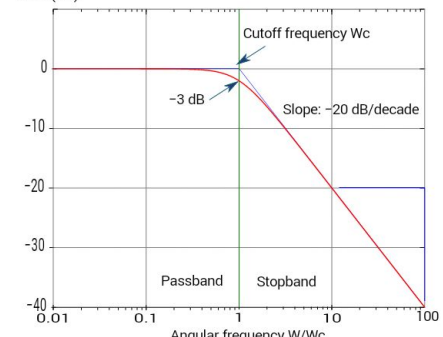

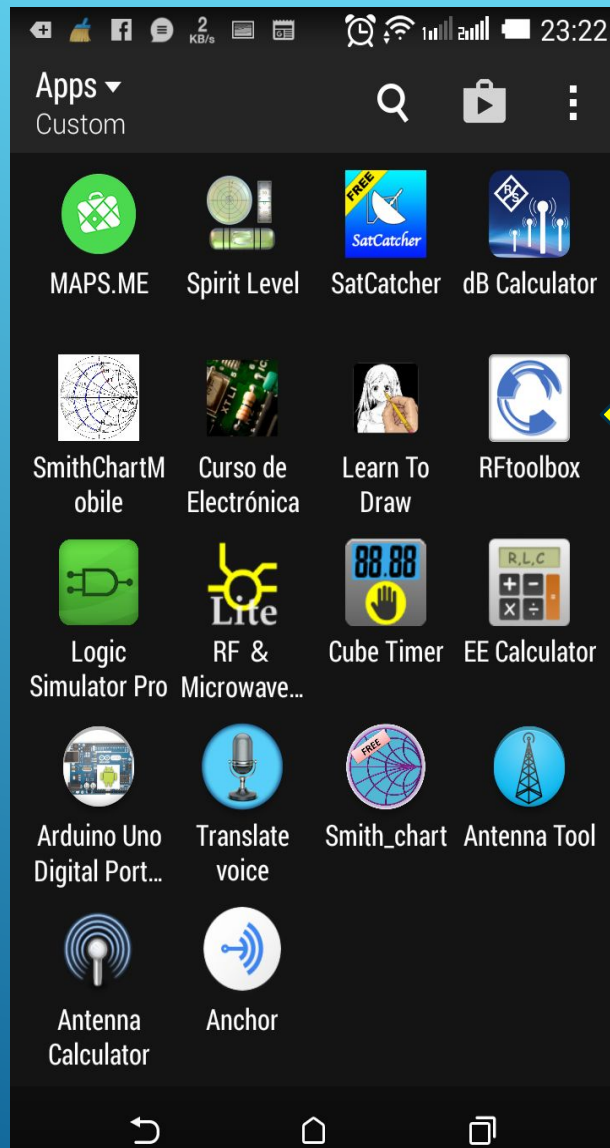
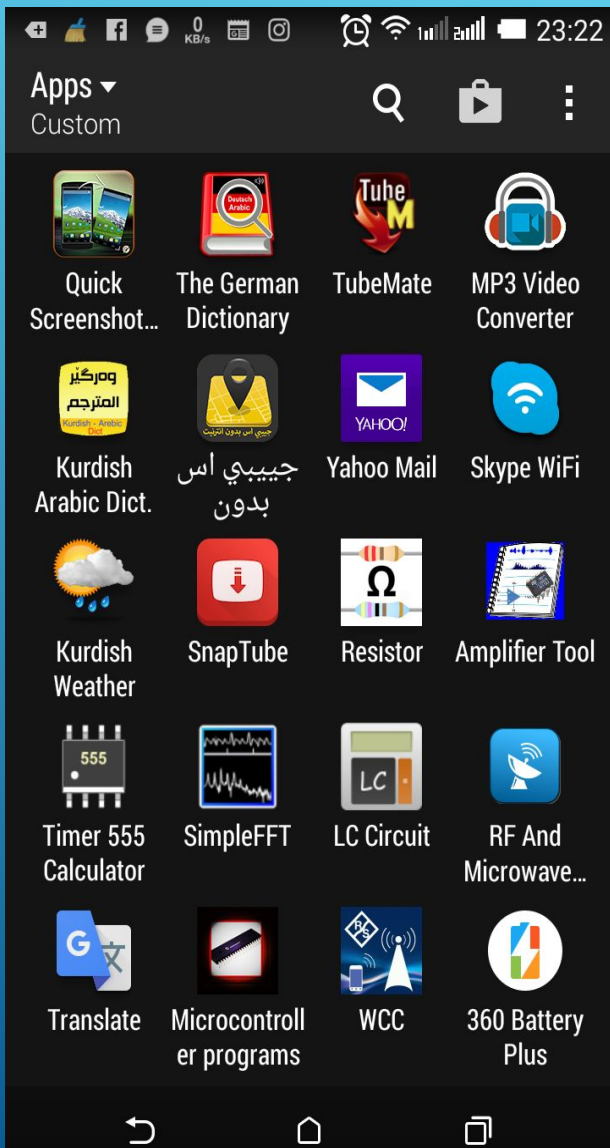

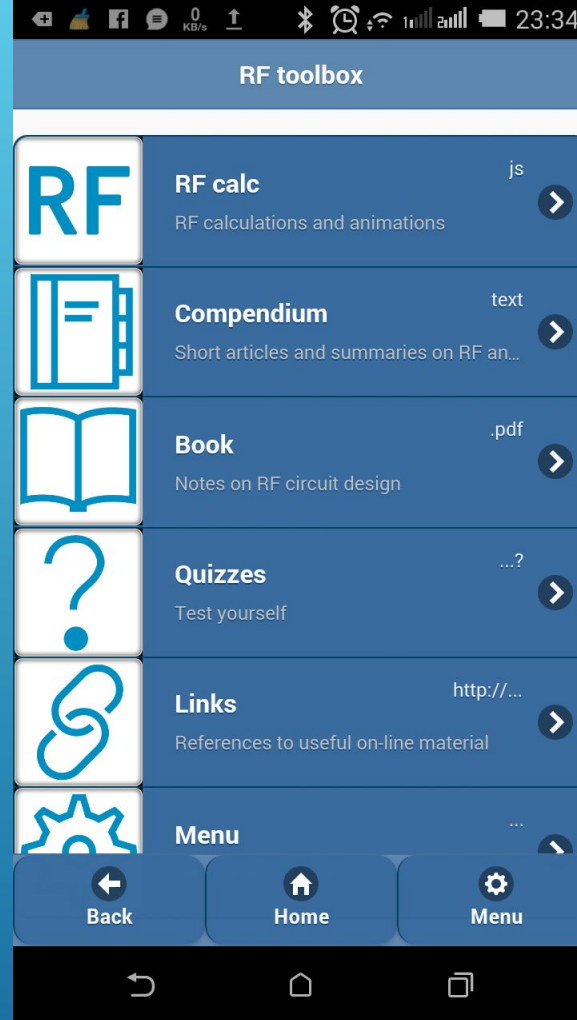

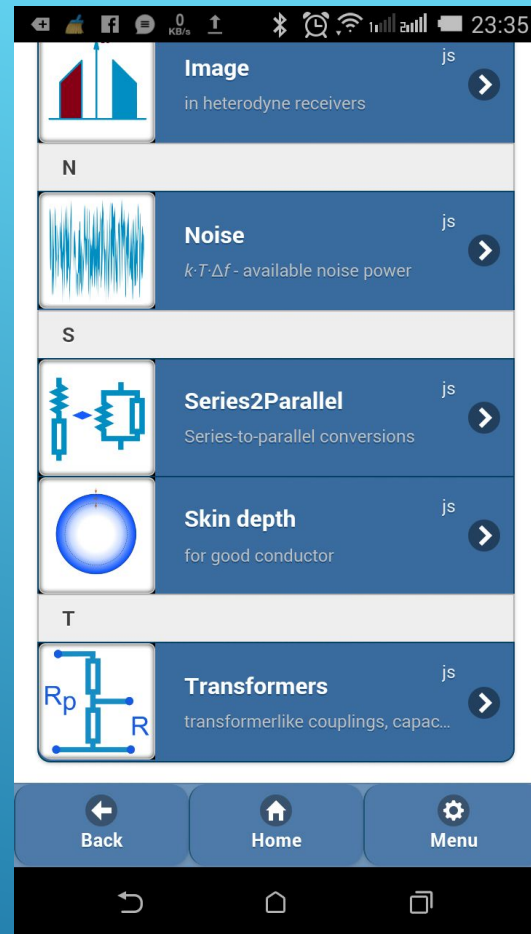
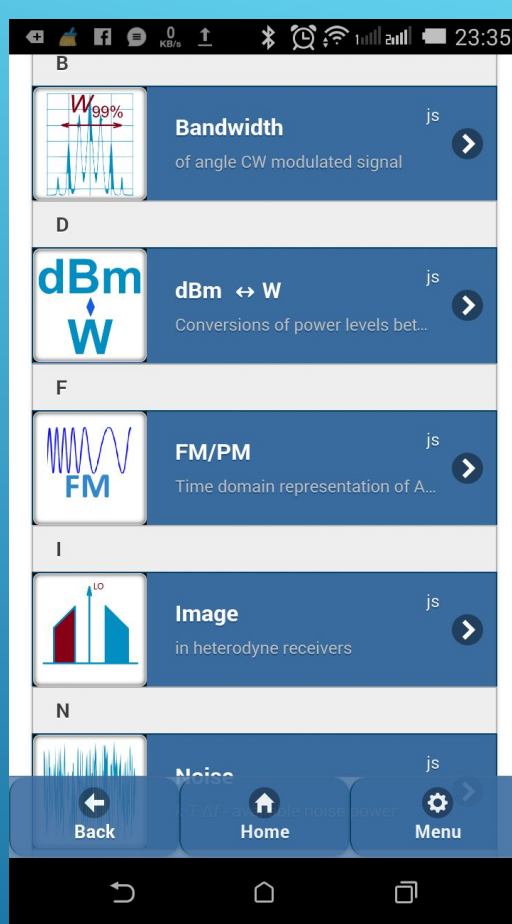
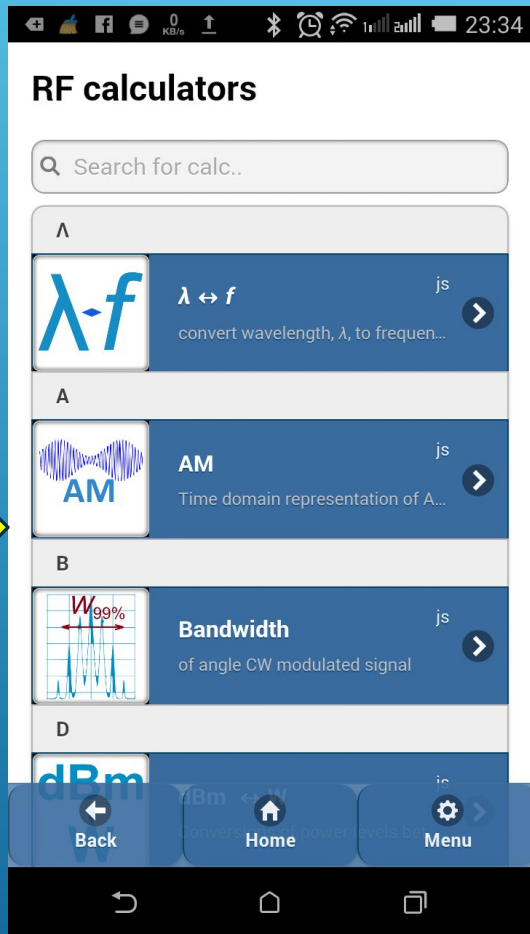

0 KB/s 08:28

DSB-LC Back

# Double Sideband Large Carrier Amplitude Modulation

Carrier wave:  $A_{c0}\cos(\omega_c t)$

Amplitude:  $A_{c0}$

Frequency:  $\omega_c$

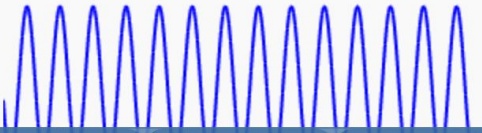

Back Home Menu

0 KB/s 08:29

## Baseband signal, $x(t)$

Choose baseband:

Sine Wave

Amplitude:  $A_x$

Frequency:  $\omega_x$



AM signal with normalized baseband ( $A_x=1$ ):

$$y(t) = A_{c0}(1+m x(t))\cos(\omega_c t)$$

Modulation index  $m = 1$

Back Home Menu

0 KB/s 08:29

## AM signal with normalized baseband ( $A_x=1$ ):

$$y(t) = A_{c0}(1+m x(t))\cos(\omega_c t)$$

Modulation index  $m = 1$



Animation speed : 0.5

Animation ON/OFF

Back Home Menu

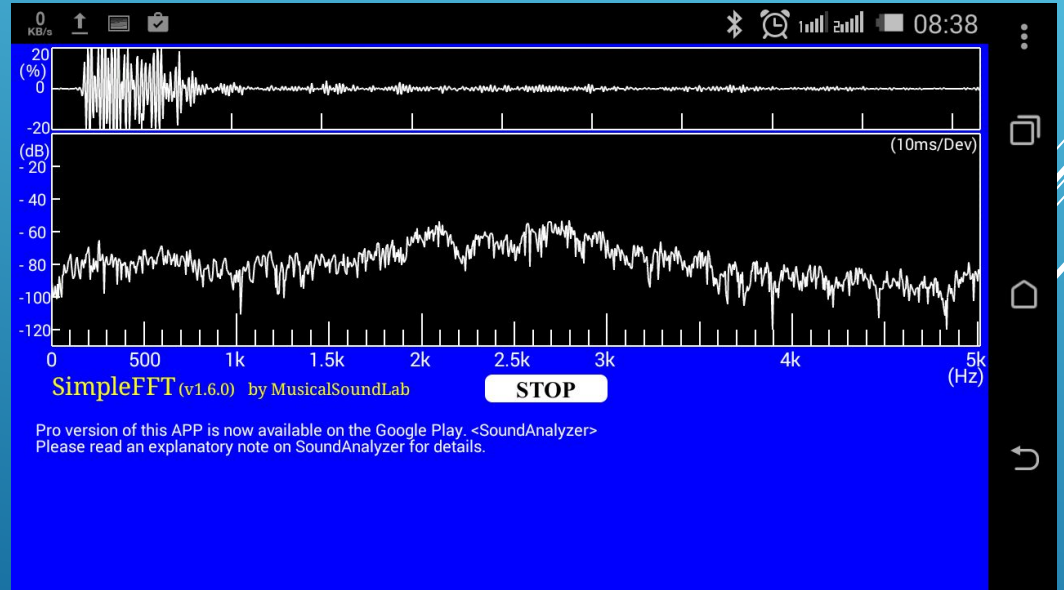
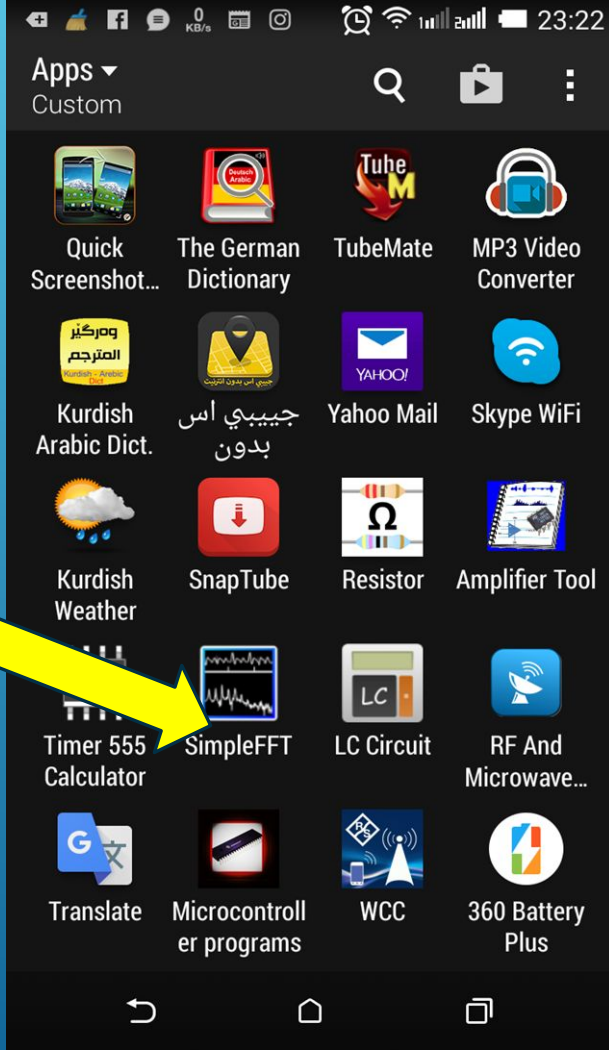

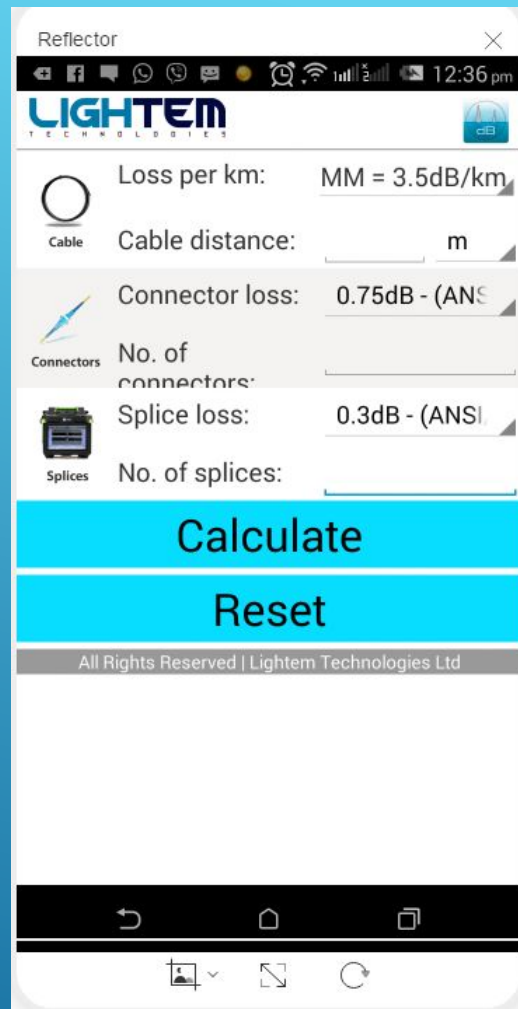
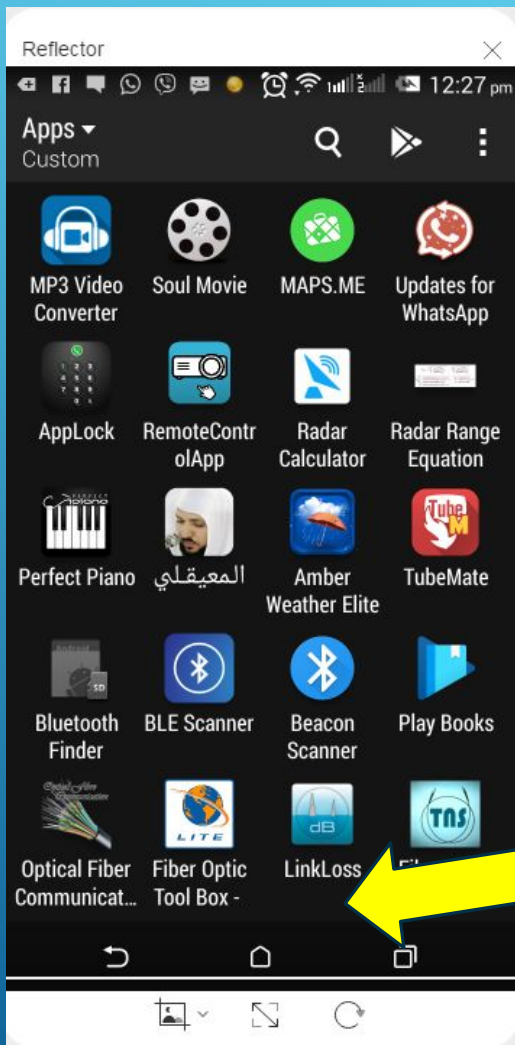

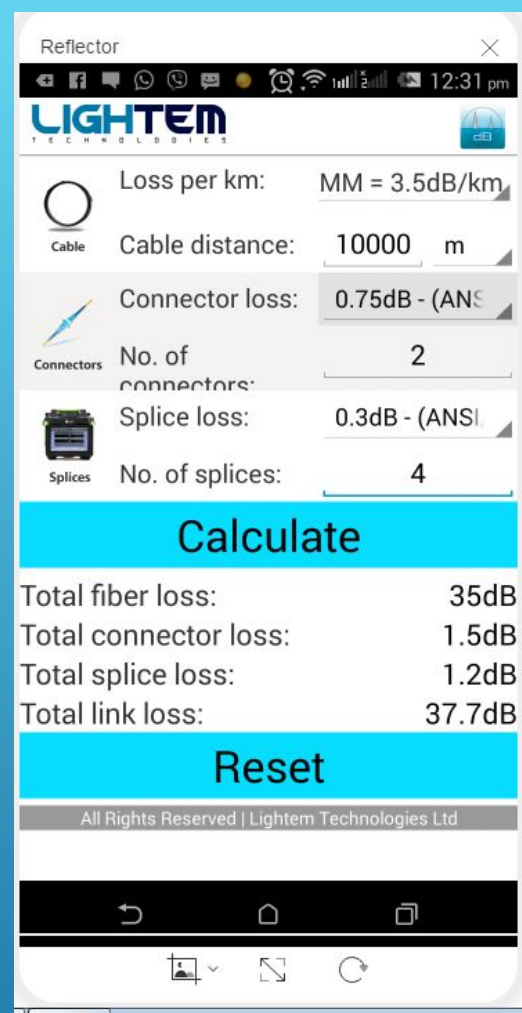
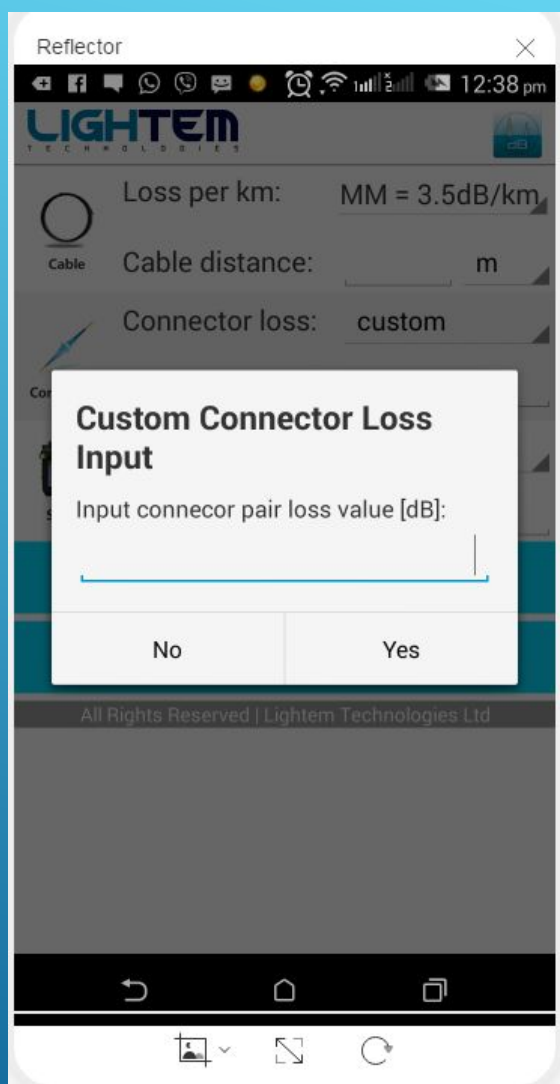
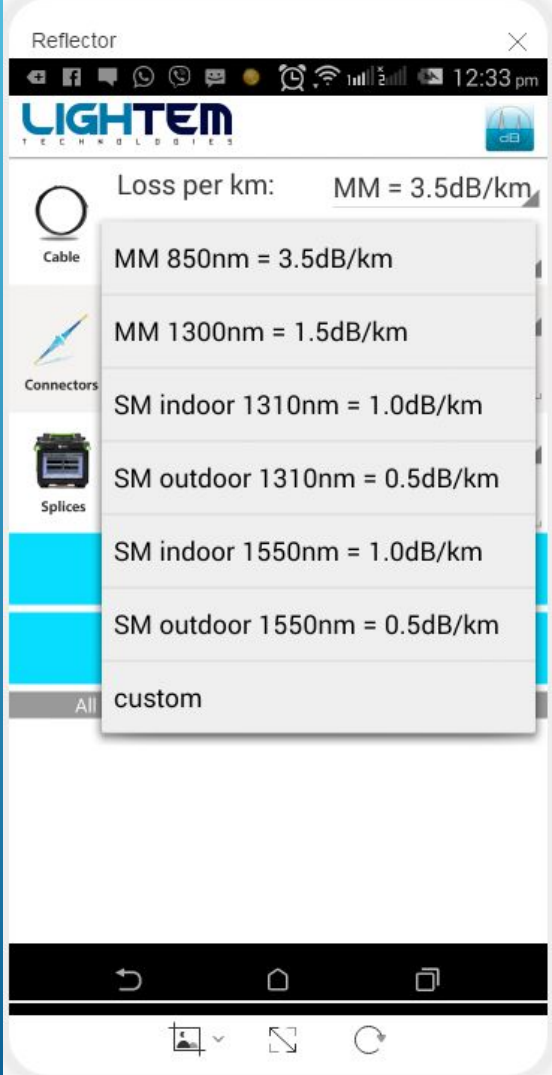

Live Show

